

Decks

Above Grade Wood Decks and Railings



Residents locating a deck on their property in HRM are required to obtain a permit. In obtaining a permit, details of locating the deck must be identified.

Example Site Plan

Indicate distances to the property lines from the proposed deck on the drawing below.

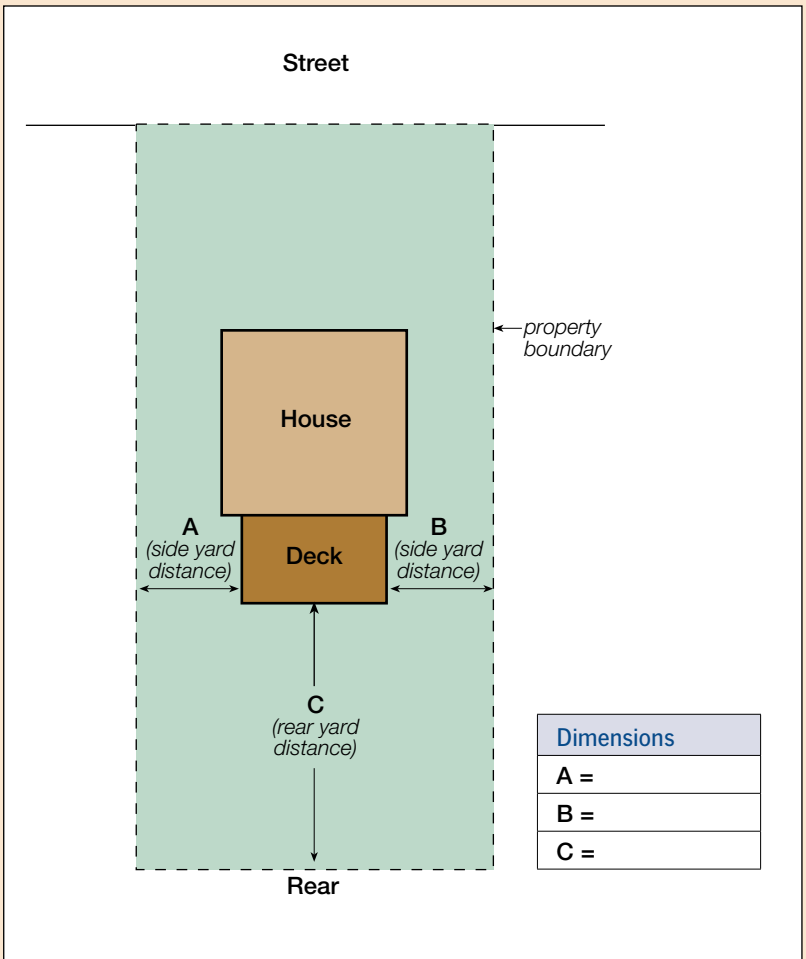

Example Construction Plan

Indicate the construction details outlined in the plan and elevation below.

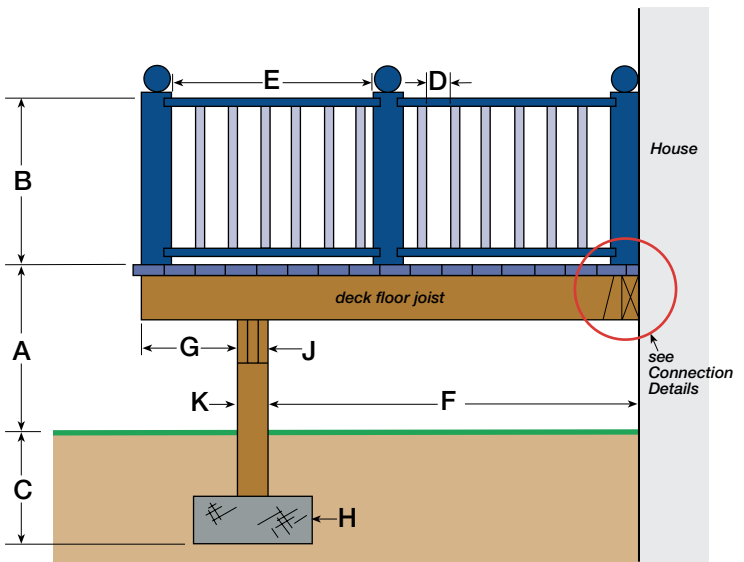
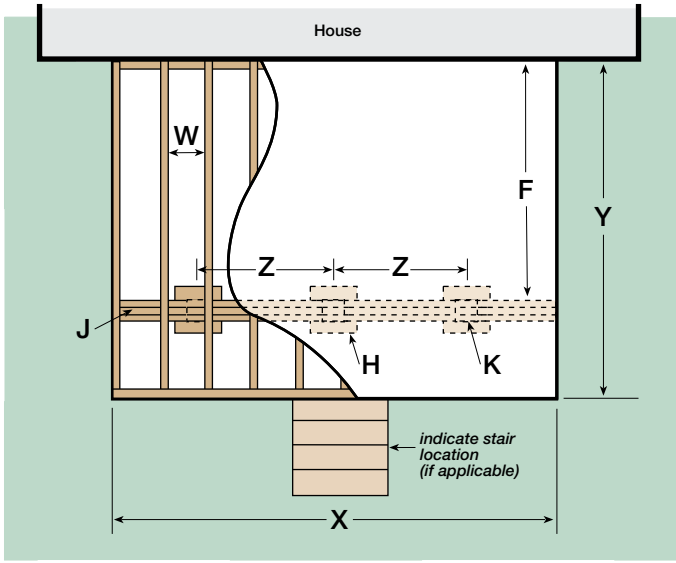

Specifications

Please provide the following dimensional information (use diagrams as a guide)

		Dimension
A	Height of deck above finished ground level	
B	Height of deck guard	
C	Footing depth below grade for frost protection - 1.2 m (4 ft) minimum	
D	Openings in the guard - maximum 100 mm (4 in) opening	
E	Distance between posts - maximum 2.4 m (8 ft) apart	
F	Span of floor joist - <i>table other side</i>	
G	Cantilever (if applicable)	
H	Column footing size - <i>table other side</i>	
J	Beam size - <i>table other side</i>	
K	Wood column supporting wood beam - minimum column size 140 mm x 140 mm (6 in x 6 in)	
W	Joist size and spacing	
X	Deck width	
Y	Deck length	
Z	Distance between support columns	

Connection Details

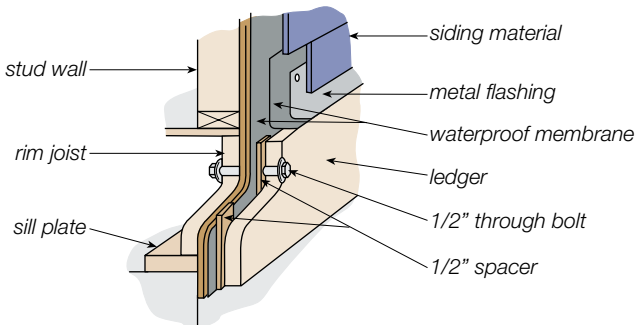

Acceptable Spans for Deck Beams and Joists

Beam (J) sizes and options.

Wood Beam Size	Supported Joist Length of Wood Joists				
	8' - 0"	10' - 0"	12' - 0"	14' - 0"	16' - 0"
	Maximum Span of Wood Beam Between Columns (Z)				
3 - 2" x 8"	10' - 0"	9' - 4"	8' - 7"	7' - 11"	7' - 5"
4 - 2" x 8"	11' - 0"	10' - 3"	9' - 8"	9' - 2"	8' - 7"
3 - 2" x 10"	12' - 10"	11' - 6"	10' - 6"	9' - 8"	9' - 1"
4 - 2" x 10"	14' - 1"	13' - 1"	12' - 1"	11' - 2"	10' - 6"
3 - 2" x 12"	14' - 11"	13' - 4"	12' - 2"	11' - 3"	10' - 6"
4 - 2" x 12"	17' - 2"	15' - 4"	14' - 0"	13' - 0"	12' - 2"

Joist (W) sizes and options.

Lumber Size	Spacing of Joists (W) (on center)	Span (F)	Spacing of joists (W) (on center)	Span (F)
2" x 6"	16"	9' - 8"	12"	10' - 8"
2" x 8"	16"	12' - 9"	12"	13' - 6"
2" x 10"	16"	15' - 7"	12"	16' - 1"
2" x 12"	16"	17' - 10"	12"	18' - 11"

Footing (H) options.

A deck may be supported with a 24" x 24" column pad on a minimum 10" sono tube. You may also use a "big foot" footing and sono tube combination.

Notes:

1. Supported joist length is half the sum of joist spans on both sides of the beam.
2. Lumber used for joists, trusses, rafters and beams shall be identified by a grade stamp to indicate its grade as determined by the *Standards Grading Rules for Canadian Lumber*.

Frequently Asked Questions

What do I need to apply for a permit?

You will need to submit with a completed permit application form

- 3 copies of the complete plans, showing all structural components.
- 3 copies of a site plan showing the proposed location of the project in relation to any other buildings on the property, the property lines, and water courses.
- All applicable fees and deposits.

How much will my permit cost?

The permit fee to construct a deck is based on \$5.50 per \$1000.00 of the estimated value of your project.

Do I need to call for inspections?

Yes, once the permit is issued, you are required to call for the following inspections:

- Footing
- Final

How long will it take to get a permit?

Once we have received your application, every effort is made to issue your permit within 5 business days. You may call any time to inquire about the status of your application. Please remember to have your application number when making inquiries or submitting additional information.

Do I need footings for my deck?

Yes, you require footings for a deck if it is attached to your house. You also require footings for a deck if it is detached and more than 2' above grade.

Where do I go to make an application?

The following HRM Customer Service Centres accept applications. They are located at:

- 636 Sackville Drive (Acadia Centre) in Sackville, 869-4380,
- 6960 Mumford Road (West End Mall) in Halifax, 490-5650,
or
- 40 Alderney Drive (Alderney Gate) in Dartmouth, 490-4435.