

HALIFAX
REGIONAL MUNICIPALITY

POOLS

*Swimming Pools
Inground and Above Ground*



Residents locating a pool on their property in HRM are required to obtain a permit. In obtaining a permit, details of locating the pool, fencing and security (ie: gates and latching devices) must be identified.

Definition

A swimming pool is defined in By-law S-700 as *an artificial body of water outside a building, excluding ponds, having more than 100 square feet of surface area that is designed or intended to be used for swimming purposes and contains or is capable of containing a water depth of more than 24 inches.*

Therefore the swimming pool by-law applies to all pools which have a diameter of 11 feet or more and are capable of containing water to a depth of 24 inches.

Example Site Plan

Indicate the distances from your property boundary to the proposed pool including the location and height of the enclosing fence.

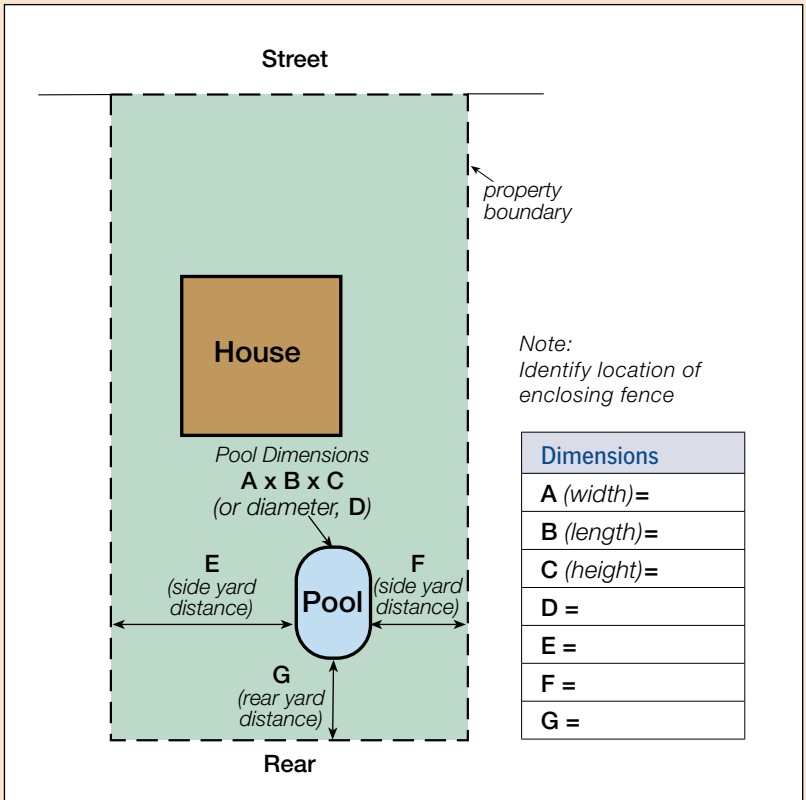

Fences and Enclosures

All swimming pools shall be completely enclosed by a 5 foot high fence that does not have any openings (between rails) that are greater than 4 inches. The fence shall be constructed so that it does not facilitate climbing.

Please note that chain link and privacy lattice have been determined to meet the above requirements.

Fence Construction

Indicate the type of fence construction to be used.

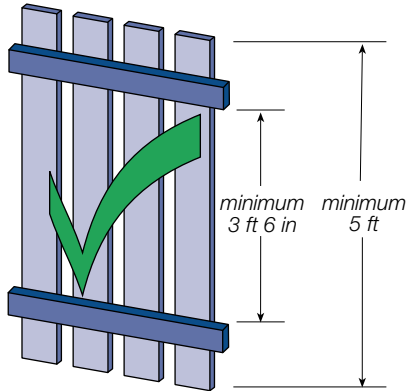
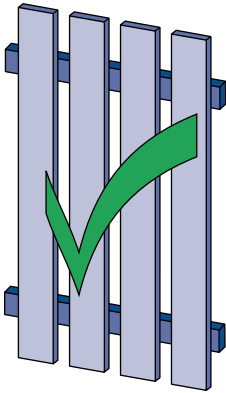

Maximum height of 6 ft 6 in when separating another property.

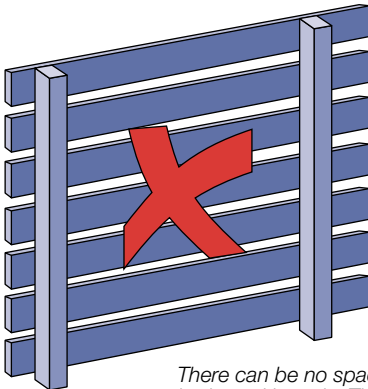

There can be no space between horizontal boards. This fence is climbable.

Automatic Latches and Self-Closing Devices

Gates must be self-closing and self-latching. *The illustrations below show examples that meet these requirements.*

Automatic Latches and Self-closing Devices

Identify type of latches to be incorporated.

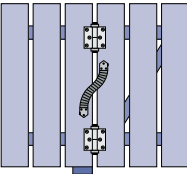
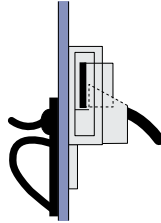
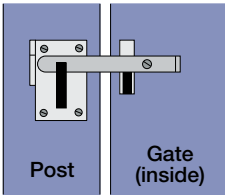
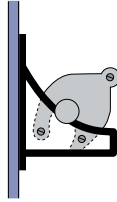
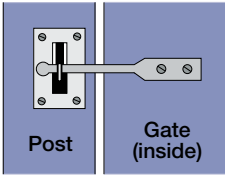

Torsion Spring

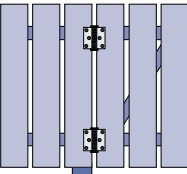

Spring Loaded Hinges

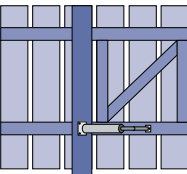

Hydraulic Closer



Example Deck Construction Plan

Indicate construction details outlined in the plan and elevation below. Also, please indicate the location of the deck on the site plan.

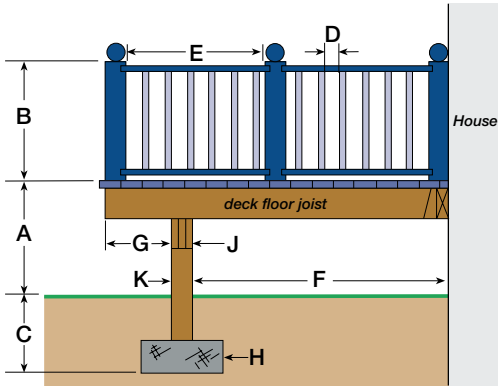
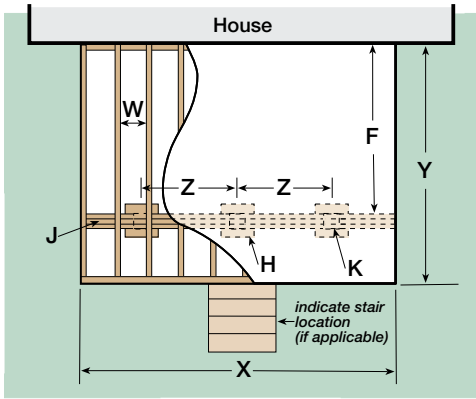

Please provide dimensional information (use diagrams as a guide)

A	Height above finished ground level	H	Column footing size
B	Height of guard	J	Beam size
C	Footing depth below grade for frost protection - 1.2 m (4 ft) minimum	K	Column supporting beam - minimum column size 140 mm x 140 mm (6 in x 6 in)
D	Openings in the guard - maximum 100 mm (4 in)	W	Joist size and spacing
E	Distance between posts - maximum 2.4 m (8 ft) apart	X	Deck width
F	Span of floor joist	Y	Deck length
G	Cantilever (if applicable)	Z	Distance between columns

Frequently Asked Questions

What do I need to apply for a permit?

You will need to submit with a completed permit application form including:

- 3 copies of the complete plans, showing all structural components.
- 3 copies of a site plan showing the proposed location of the project in relation to any other buildings on the property, the property lines, and watercourses.
- All applicable fees and deposits.

How much will my permit cost?

The permit fee to install a pool is based on \$5.50 per \$1000.00 of the estimated value of the project with a minimum \$25.00 fee.

Do I need to call for inspections?

Yes, when the project is complete, you are required to call for a final inspection. The pool and the fence must be installed prior to this inspection.

How long will it take to get a permit?

Once we have received your application, every effort is made to issue your permit within 5 business days. You may call any time to inquire about the status of your application. Please remember to have your application number when making inquiries or submitting additional information.

Do I require a fence if I build a deck around my pool?

If the combined height of your deck and rail exceeds 5' from grade, you do not require a separate enclosure. If there are steps from the deck to the ground, a 5' high self-closing, self-latching gate is required at the top of the stairs.

Where do I go to make an application?

The following HRM Customer Service Centres accept applications.

- 636 Sackville Drive (Acadia Centre) in Sackville, 869-4380,
- 6960 Mumford Road (West End Mall) in Halifax, 490-5650,
- or
- 40 Alderney Drive (Alderney Gate) in Dartmouth, 490-4435.