

*This page will be public facing

LOCATION OF CONSTRUCTION

| | | |
|--|-------------|---|
| Building or Project Name (if applicable) | | |
| Street Number | Street Name | Suite/Unit Number |
| Community | | |
| Other Location Information (if no civic number assigned) | | |
| Associated permits numbers | Description | Estimated project start date / end date |

ANTICIPATED NOISE EVENT(S)

Describe the activity, including the type of noise impacts, and duration of the expected after/before hours noise events.

REASON FOR EXEMPTION

Description of why noise within the prohibited hours of the N-200 By-law is required.

*This page will be public facing

MITIGATION MEASURES – SITE ORGANIZATION

Describe what site-specific steps you will take to reduce the impact of the noise during all hours of construction. (i.e. measures could include locating construction equipment away from residences, discouraging queuing of vehicles prior to site opening etc.)

MITIGATION MEASURES - EQUIPMENT

Describe what equipment related steps you will take to reduce the impact of the noise during all hours of construction. (i.e. measures could include sound barriers to muffle generators, scheduled inspections of equipment's condition etc.)

*This page will be public facing

MITIGATION MEASURES - OTHER

Describe what other steps you will take to reduce the impact of the noise during all hours of construction. (i.e. measures could include training, schedule after hours truck routes, solid hoarding and other measures not otherwise listed.)

SUPPORTING DOCUMENTATION (IF APPLICABLE)

List any attachments supporting the noise mitigation that are included with this application (i.e. site plan, sound attenuation material/system specifications).

- 1.
- 2.
- 3.
- 4.

AUTHORIZED SIGNATURE

As the owner or the designate appointed by the owner, I shall at all times observe and comply with, and endeavor to ensure strict observance of and compliance with all statutory requirements, rules, regulations, by-laws, terms and conditions, which are related to this exemption.

| | | |
|----------------------------|--|-------------------|
| Name of owner or designate | Signature of owner or designate  | Date (yyyy-mm-dd) |
|----------------------------|--|-------------------|

CUNARD Block
1325 Lower Water St,
Halifax, NS

Prepared by Geoff MacLean, P.Eng.

Job No. 35804

CONSTRUCTION MANAGEMENT PLAN

| REVISION # | DATE | DESCRIPTION |
|------------|----------|-------------------|
| 0 | FEB 2021 | ISSUED FOR REVIEW |



36 Oland Crescent
Bayers Lake Business Park
Halifax, Nova Scotia B3S 1C6
www.sdmm.ca

t: 902 455-1537
f: 902-455-8479
c: 902-789-6374
e: gmaclean@sdmm.ca

Table of Contents

| | |
|--|---|
| Section 1: Introduction | 1 |
| 1.1: Project Description and Objectives | 1 |
| 1.2: Project Contact Information..... | 2 |
| Section 2: Project Schedule and Logistics..... | 2 |
| 2.1: Schedule..... | 2 |
| 2.2: Key Dates | 2 |
| 2.3: Hours of Work..... | 2 |
| Section 3 – Relevant Regulations & Guidelines..... | 3 |
| 3.1: Occupational Health & Safety Regulations | 3 |
| 3.2: Municipal Regulations & Guidelines | 3 |
| Section 4: Vehicle Management..... | 3 |
| 4.1: Vehicular Traffic Control..... | 4 |
| 4.2: Haul Route and Staging Areas | 4 |
| 4.3: Vehicular Traffic Notifications | 4 |
| 4.4: Emergency Vehicles | 4 |
| 4.5: Parking | 4 |
| 4.6: Bus Stops..... | 5 |
| 4.7: Hazard Assessment..... | 5 |
| Section 5: Pedestrian Management | 5 |
| 5.1: Pedestrian Protection | 5 |
| 5.2: Pedestrian Safety | 5 |
| 5.3: Pedestrian Traffic Notifications..... | 5 |
| 5.4: Visually Impaired Persons..... | 5 |
| 5.5: Accessibility..... | 6 |
| 5.6: Hazard Assessment..... | 6 |
| 5.7: Pedestrian Management Plans Rendering (PMPR) Signage..... | 6 |
| 5.8: Pedestrian Detour Wayfinding Signage..... | 6 |
| Section 6: Encroachments & Disruptions | 6 |
| 6.1: Demolition | 6 |
| 6.2: Site Work..... | 6 |

| | |
|--|----|
| 6.3: Site Services Connection..... | 6 |
| 6.4: Construction Management Plan Element Inspection and Maintenance | 7 |
| 6.5: Changes to the Construction Management Plan | 7 |
| Section 7: Environmental Factors..... | 7 |
| 7.1: Damage to HRM Infrastructure..... | 7 |
| 7.2: Protection of Trees | 7 |
| 7.3: Line Painting and Temporary Crosswalks..... | 8 |
| 7.4: Street and Right-of-Way Cleaning..... | 8 |
| 7.5: Protection from Inclement Weather..... | 8 |
| 7.6: Storm Water Management..... | 8 |
| 7.7: Noise, Dust and Emission Control | 8 |
| 7.8: Rodent Control..... | 8 |
| Section 8: Site Protection & Hoarding..... | 9 |
| 8.1: Barriers and Fences..... | 9 |
| 8.2: Snow removal | 9 |
| 8.3: Gates Access & Egress | 10 |
| 8.4: Hoarding Aesthetics..... | 10 |
| 8.5: Sight Lines | 10 |
| 8.6: Project Information and Contacts | 10 |
| Section 9: Lifting, Hoisting, and Crane Operations | 10 |
| 9.1: Crane Use Overview | 10 |
| 9.2: Transport Canada and Nav Canada Regulations..... | 11 |
| 9.3: Aerodromes | 11 |
| Section 10: On-Site Safety and Security | 11 |
| 10.1: Site Safety and Security Overview..... | 11 |
| 10.2: Material Handling: Loading, Unloading, Delivery and Storage..... | 11 |
| 10.3: Emergency Access & Egress..... | 12 |
| 10.4: Security Site Lighting | 12 |
| 10.5: Smoking Areas | 12 |
| 10.6: Fire Suppression Systems | 12 |
| Section 11: Pre-Construction Consultation & Meeting..... | 12 |
| 11.1: Pre-CMP Community Consultation | 12 |

| | |
|---|----|
| 11.2: Project Information and Contacts | 12 |
| 11.3: Preconstruction Meeting..... | 12 |
| 11.4: Construction Notification | 13 |
| Section 12: Summary | 13 |
| Appendix A – Encroachment Plan | A |
| Appendix B – Traffic Control Plans (TCP)..... | B |
| Appendix C – Haul Route Plan | C |
| Appendix D – Pedestrian Management Plan (PMP)..... | D |
| Appendix E – HRM Tree Detail..... | E |
| Appendix F – Barrier, Fence & Gates Information | F |
| Appendix G – Hoarding Information | G |
| Appendix H – Project Information Board | H |
| Appendix I – Project Safety Signage | I |
| Appendix J – Project Signage Specifications..... | J |
| Appendix K – Sample Traffic Notification Letter | K |
| Appendix L – Vehicular and Pedestrian Hazard Assessment | L |
| Appendix M – Community Consultation Records | M |
| Appendix N – Rodent Control Plan | N |
| Appendix O – CMP’s TCP & PMP Inspection Records | O |
| Appendix P – Concrete Delivery Schematic..... | P |
| Appendix Q – Crane Information..... | Q |



Prepared by

G.K. MacLean, P. Eng.

In consultation with the developer, contractor and traffic control company.

Section 1: Introduction

1.1: Project Description and Objectives

Southwest Construction are going to build the Cunard building on Lower Water Street in Halifax. The land is under lease agreement between Develop Nova Scotia (DNS) and Southwest Properties Limited. The proposed Cunard building will be located at 1325 Lower Water Street, currently a surface public parking lot with access from Lower Water Street. As per the development agreement the planned building will be a 16-storey 238-unit multi residential building with commercial space and retail space on the lower levels and 3 levels of parkade parking accessed from Lower Water Street. This CMP has been prepared to address site work, services and building construction.

Where the building is planned to not have any below grade levels, the planned slab-on grade pile foundations, will avoid deep excavations however the building is planned to be set tight to the street line. For public safety during site work and building construction, they are proposing to hoard off the sidewalk directly in front of the project and utilize a portion of the one-way street for a truck layby area. This encroachment area will be wide enough to accommodate their exterior construction elevator, planned to be set at the front face of the building to receive and move building materials delivered to site, minimizing construction timelines.

A protected on-street pedestrian route will be provided around the encroachment to maintain public access on this side of the street. This will result in pay parking across the street from the project being closed while the bicycle lane is merged with vehicle traffic to travel around the protected pedestrian route. The developer is also proposing to install a pedestrian bridge on the boardwalk to further maintain pedestrian traffic.

The construction site is located on Lower Water Street between Bishop and Morris Streets. The project borders mixed used commercial-residential building along its northern property line that houses the Southwest Properties office, Quickplus Convenience and other businesses, a commercial property along its southern property line that houses Nova Scotia Power and the Halifax harbour on the eastern property line. West of property across Lower Water is the Waterfront Place a multi residential building. All neighbouring properties will remain undisturbed throughout all construction phases and all neighbours will be notified and updated on construction ahead of time.

This CMP document is intended to be an evolving document to help guide the project team to mitigate impacts to the adjacent community before they arise and to address unforeseen issues. SDMM, together with the developer, contractor, and traffic control company, have prepared this Construction Management Plan (CMP) following HRM's CMP (2020) guidelines and administrative order (2018-005-ADM) in an effort to reduce potential negative impacts on the surrounding community, due to construction activities for this project.

The most up-to-date version of this document will be kept on-site at all times during construction. Should ownership or contracting services change throughout the course of this project, HRM will be notified immediately and new parties will be required to comply with the approved CMP in writing.

1.2: Project Contact Information

The project team for the proposed development consists of:

| Role | Name | Contact | Address | Phone |
|-------------------------|---|----------------|---|--|
| Developer | Southwest Construction Management Limited | Steve Seal | 1475 Lower Water street, Suite 100, Halifax, NS B3J 3Z2 | (902) 210-9543 |
| Construction Manager | Southwest Construction Management Limited | Adam Fraser | 1475 Lower Water street, Suite 100, Halifax, NS B3J 3Z2 | (902) 580-5852 (24hr Emergency Contact) |
| Site Contractor | Atlantic Road Construction and Paving | Greg MacDonald | 6 Belmont Avenue, P.O. Box 89 Eastern Passage, NS B3G 1M7 | (902) 830-6411 |
| Traffic Control Company | Frontline Traffic Services | Phil Pruneau | 6 Belmont Avenue, P.O. Box 89 Eastern Passage, NS B3G 1M7 | (902) 818-5548 |
| Rodent Control Company | Rentokil Pest Control | | 51 Duke Street, Bedford, NS B4A 2Z2 | (902) 789-7368 |

Section 2: Project Schedule and Logistics

The following is a brief summary of anticipated major project milestones broken down by phase:

2.1: Schedule

| Project Phase | Start Date | | End Date | Time Period |
|--------------------------------|----------------|---|-----------------|-------------|
| Rodent Control Program | March 1, 2021 | - | March 15, 2021 | 2 weeks |
| Demolition | n/a | - | n/a | n/a |
| Site work/piling phase | March 15, 2021 | - | July 15, 2021 | 4 Months |
| Substructure | June 10, 2021 | - | August 31, 2021 | 3 Months |
| Superstructure | July 14, 2021 | - | July 31, 2023 | 24 Months |
| Flat Works | June 1, 2023 | - | July 31, 2023 | 2 Months |
| Service Install & Abandonments | June 1, 2021 | - | June 30, 2021 | 1 Month |

2.2: Key Dates

- Take-over of encroachment March 1, 2021
- Finish encroachment July 31, 2023
- Duration of encroachment: 27 months
- Temporary Lane Closures:
 - Service work June 2021 (weekends only)
 - Crane Installation June 2021
 - Crane removal Nov 2022

2.3: Hours of Work

Work will generally take place during normal working hours as outlined in HRM's Noise By-Law and Traffic Control Manual Supplement; these are noted below.

- Monday to Friday: 7:00 a.m. – 9:30 p.m.
- Saturdays: 8:00 a.m. – 7:00 p.m.

- Sundays & Statutory Holidays: 9:00 a.m. – 7:00 p.m.
- Servicing Work: Noted above

Although work is not expected to be required outside of the times listed above, if, for any reason, work is anticipated to be required outside of these hours, the contractor will apply to HRM for approval 5 business days (minimum) in advance of such work and obtain approval prior to proceeding. It is noted that HRM's Noise By-Law cannot be altered without HRM council approval; work must adhere to the Noise By-Law.

Section 3 – Relevant Regulations & Guidelines

3.1: Occupational Health & Safety Regulations

This CMP shall be utilized in agreement with all applicable Provincial and Federal Occupational Health and Safety Regulations. At a minimum, construction activities must at all times meet the standards of:

- a) National Building Code of Canada, as adopted and modified under the Building Code Act and the Nova Scotia Building Code Regulations made under that Act;
- b) Nova Scotia Occupational Health and Safety Act, and the Nova Scotia Occupational Safety General Regulations made under that Act;
- c) The Transportation Association of Canada (TAC)'s Manual of Uniform Traffic Control Devices for Canada (MUTCDC); and
- d) Nova Scotia Temporary Workplace Traffic Control Manual (NSTCM).

3.2: Municipal Regulations & Guidelines

In addition to the Provincial and Federal standards referenced in Section 3.1, this CMP shall be utilized in agreement with and meet, at a minimum, the standards of all relevant municipal by-laws including, but not limited to, the following:

- a) HRM Design Guidelines
- b) HRM Standard Details
- c) S-300 Streets;
- d) E-200 Encroachments;
- e) B-201 Building;
- f) N-200 Noise;
- g) T-600 Trees;
- h) S-900 Controlled Access Streets;
- i) T-400 Truck Routes;
- j) W-101 Discharge into Public Sewers;
- k) B-600 Blasting; and
- l) HRM TCM Supplement.
- m) G-200 Grade Alteration and Stormwater Management
- n) Admin Order 2018-005-ADM regarding encroachments
- o) Admin Order 2020-010-OP regarding stormwater management standards for development activities

Section 4: Vehicle Management

Prior to any construction activity, all temporary workplace traffic control devices and signage will be in place as per the Nova Scotia Temporary Workplace Traffic Control Manual (latest edition). The traffic control company will install the signage and ensure that they are maintained throughout the project. This project's Traffic Control Plans (TCPs) are listed in the Appendix.

4.1: Vehicular Traffic Control

Various Traffic Control Plans (TCP) have been prepared by the traffic control company and are provided in the Appendix.

We are proposing to narrow Lower Water Street's one-way travel lane, directly in front of the project while down to a 4.5m travel lane throughout most phases of construction, we note a 4.0m wide travel lane is required for transport truck traffic anticipated from the port. Only during installation of the tower crane, service work and removal of the tower crane do we anticipate short term temporary road closures to vehicles being required. Please refer to the appendices for required traffic control plans and Section 2.2: Key Dates.

4.2: Haul Route and Staging Areas

The truck Haul Route Plan has been prepared by the traffic control company and is provided in the appendix. The selected route is intended to minimize traffic congestion and maximize pedestrian safety. During excavation and construction vehicles will enter and exit the site at the gate locations which will be clearly marked for function.

Siteworks and piling operations will be contained to private property with site accessed from an existing driveway.

Concrete operations will be contained to private property between the building footprint and the boardwalk. Both concrete delivery and pump trucks will be stationed on private property away from Lower Water Street. We anticipate these deliveries to drive into the site from the existing driveway. Please refer to the concrete delivery schematic in the appendix.

Building material deliveries will be contained within the Lower Water Street encroachment area; we anticipate these delivery trucks to back into the encroachment area to reach the elevator lift stationed in front of the building.

Being a LEED Gold building the site garbage will need to be separated on site, this is planned to be stationed south of the elevator lift; we anticipate collection of these bins to take place from the south gate.

4.3: Vehicular Traffic Notifications

Should any traffic disruptions be required, notifications will be distributed to HRM, the Port and properties in the impacted area a minimum of five (5) days in advance of vehicular traffic closures. Refer to sample notification letter in the appendix.

4.4: Emergency Vehicles

In the event of unforeseen emergency situations, the site will remain accessible to emergency vehicles at all times.

4.5: Parking

On street parking is not permitted directly in front of the project site this is currently a bicycle lane. Two (2) accessible parking spaces and four (4) on street parking spaces opposite the site will need to be closed to allow vehicle, bicycle and pedestrian traffic to travel past the encroachment.

It is noted that passenger vehicles are not permitted to park within any encroachment areas. To minimize parking requirements in adjacent neighbourhoods, on-site workers will rent parking spaces from adjacent parking structures and workers will be encouraged to carpool or rely on public transit.

No alternate parking is planned or feasible for this project. Resulting in a parking new loss during construction.

4.6: Bus Stops

Bus service on Lower Water Street will remain, 3.5m wide minimum travel lane width is required to accommodate bus service, we are anticipating a travel lane that is wider than this minimum.

4.7: Hazard Assessment

A vehicular and pedestrian hazard assessment is provided in the appendix. Any additional site hazards identified or encountered after work has commenced will be added to this list. All personnel on-site will be required to review this list and encouraged to identify additional potential hazards and hazard mitigation methods.

Section 5: Pedestrian Management

A Pedestrian Management Plan (PMP) has been prepared by the traffic control company and is provided in the appendix.

Throughout sitework and building construction, the project will close the sidewalk and a portion of the street lane in front of the development. This is to ensure construction and deliveries are kept a safe distance from pedestrians with a protected on street pedestrian route provided around the encroachment. Pedestrian traffic along the Harbourside boardwalk will be directed to the proposed pedestrian bridge. Pedestrians will be encouraged to utilize the existing crosswalks at the intersections of Bishops and Morris Street if required.

5.1: Pedestrian Protection

Pedestrians will be protected by physically distancing them from the project and vehicle traffic. The construction site will be delineated by a construction fence that will be anchored to F-type concrete jersey barriers. Pedestrians will travel between the F-type concrete barriers and fence while passing under the walkthrough bracket arm supports which anchor the fence panels to the concrete barriers. Fencing will be covered with black mesh coverings to block passers-by view of the construction site. This Refer to the appendix for examples of the barriers, bracket arms and black mesh covering.

5.2: Pedestrian Safety

Pedestrian safety will be maintained by implementing appropriate signage as shown on the PMP. All navigation and safety signage indicating alternative sidewalks and potential hazards will be inspected and maintained regularly.

5.3: Pedestrian Traffic Notifications

Notifications will be distributed to HRM and properties in the impacted area a minimum of five (5) days in advance of pedestrian traffic impacts.

5.4: Visually Impaired Persons

In keeping with Canadian National Institute for the Blind (CNIB) requirements and as outlined on their 'Clearing Our Path' website; various items will be incorporated into the pedestrian management signage and barriers. Such as, high visibility contrasting colours with appropriate font types (mix of upper and lower-case lettering), font sizes (between 16mm to 51mm) and sign colours (orange background with black lettering or white background with black lettering).

The contractor will use bright orange sawhorse barricades complete with bold-font signage to identify sidewalk termination points. Sawhorse barriers will incorporate lower cross members, painted and marked consistent with the rest of the sawhorse, these added cross members will be placed near the ground to aid visually impaired persons using a cane. Reflective tape will also be placed on the ends of fencing, hoarding, sawhorse barricades, and concrete barriers to help delineate pedestrian routes and disruptions. Signage and tape colours will vary but will comply with

the colour/brightness contrast as outlined by the CNIB website; examples are black/white, orange/black or dark red/white combinations.

5.5: Accessibility

High visibility signage will be used to assist pedestrians to easily navigate around all project related blocked sidewalks.

5.6: Hazard Assessment

A vehicular and pedestrian hazard assessment is provided in the appendix. Any additional site hazards identified or encountered after work has commenced will be added to this list. All personnel on-site will be required to review this list and encouraged to identify additional potential hazards and hazard mitigation methods.

5.7: Pedestrian Management Plans Rendering (PMPR) Signage

The need for a rendered map displayed for pedestrians showing the detoured pedestrian routes are not anticipated for this project given that pedestrian traffic will remain around the encroachment area.

5.8: Pedestrian Detour Wayfinding Signage

The need for pedestrian wayfinding signage directing pedestrians to adjacent businesses is not anticipated for this project given the location. Pedestrian traffic will remain around the encroachment area.

Section 6: Encroachments & Disruptions

For public safety during site work and building construction we are proposing that the project compound incorporate the public sidewalk and a portion of the one-way street lane directly in front of the project. This will move pedestrians to a protected on street route alongside the encroachment, bicycles will need to share the road with vehicle traffic. The encroachment is planned to be delineated by fencing that is anchored to the interlocking F-type concrete barriers that separate the pedestrians from vehicles via a walkthrough support arm. This fencing will be covered with a black HDPE mesh. This encroachment is to keep the public away from the construction site as well as provide additional room for workers and deliveries within the encroachment.

Throughout the project, fencing will not obstruct vehicle sight lines.

Should any utility or traffic disruptions be required, the contractor will first apply to HRM for approval, a minimum of five (5) business days in advance of such work and will then notify neighbours of these disruptions in a timely fashion.

6.1: Demolition

Building demolition is not required for this site.

6.2: Site Work

Parking for this building will be set at street level, avoiding deep excavations, with a slab on grade footing arrangement positioned on piles. Piles that will be driven into the ground from the existing site elevations.

6.3: Site Services Connection

This includes installation of new water and sewer laterals to their respective mains as well as decommissioning existing laterals which will be abandoned and capped. The service installs will require modifications to the encroachment with temporary workplace signage incorporated (refer to the Traffic Control Plans (TCP) in the appendix), we are anticipating that the street will need to be closed to through traffic during these service installs. The target dates for this work are provided in the “Key Dates” section above with time of installations adhering to the Noise By-Laws noted above. The

intent will be to complete this servicing work and reinstate the street as quickly as possible in order to minimize disruptions to the public. It is anticipated that weekend work may be required by Halifax Water for mainline tie-ins and abandonments.

Before scheduling site services connections, the contractor will notify HRM, HW and all neighbouring properties, of the intended timeline for this work. A sample notification letter is included in the appendix.

The contractor intends to reinstate the street cut during the season of work. It is noted that street cuts cannot be left gravel or open. HRM reinstatement specifications must be met and the travel way must be hard surfaced prior to reopening to the public. Asphalt, concrete curb and sidewalk reinstatement must be completed within 72 hours of disturbance and will be considered temporary if reinstated after October 31st or prior to May 1 in which case permanent reinstatement will be completed by June 15.

6.4: Construction Management Plan Element Inspection and Maintenance

Construction management plan elements will be inspected daily to ensure continued adherence to this CMP. Any deficiencies identified will be reinstated immediately. A CMP's TCP & PMP inspection report summary will be completed for the project, including information on what maintenance activities were conducted. This report must be kept on site at all times and be available to HRM upon request.

6.5: Changes to the Construction Management Plan

All departures from the CMP regardless of the significance must be submitted to the Municipality 5 days in advance for review and approval. Any required changes or modifications to the approved CMP will be submitted to HRM for review and approval prior to implementation.

Section 7: Environmental Factors

7.1: Damage to HRM Infrastructure

Existing sidewalks within the encroachment area will be completely replaced. It is anticipated that sidewalks across the street will not be impacted by excavation or other construction activities. However, while efforts will be made to avoid damage, it is anticipated that additional portions of existing curbs, gutters, and sidewalks may become damaged during the construction process which would require repairs or replacement. Pending HRM's review prior to and after construction and subject to damage due to construction activities, the landowner acknowledges that items may require to be fully replaced rather than repaired. The landowner also acknowledges that any costs incurred to repair or replace this public infrastructure are the responsibility of the owner.

For reinstatement timeline requirements, it is noted that asphalt, concrete curb and sidewalk reinstatement must be completed within 72 hours of disturbance and will be considered temporary if reinstated after October 31st or prior to May 1 in which case permanent reinstatement will be completed by June 15 of the following construction season.

7.2: Protection of Trees

There are no street trees within the public right-of-way directly adjacent to the project site. It is noted that HRM street trees shall not be touched prior to approval and/or compensation agreements between the developer and HRM Urban Forestry are in place. Adjacent street trees are to be protected during construction in accordance with the HRM Tree Bylaw (T-600). Refer to HRM tree protection detail in the appendix.

7.3: Line Painting and Temporary Crosswalks

Temporary line painting is not anticipated for this project.

7.4: Street and Right-of-Way Cleaning

The portion of public street adjacent to the project will be cleaned daily of any debris from trucks and silt, dirt, or rock that migrates beyond the encroachments. A sweeper truck will be utilized as required. Rock pads will be installed and maintained at site entrances behind the curb line and gates as needed to knock dirt free from truck tires with aim to reduce off tracking of site soils. It is noted that where the developer plans to utilize the roadway for their encroachment the developer is responsible to clear snow from the street side of the jersey barriers refer to section 8.2 below.

7.5: Protection from Inclement Weather

To protect the public from construction debris during inclement weather, the project site will be enclosed by fencing complete with dust control covering, the site will be regularly reviewed and cleaned, with loose items secured when not in use.

It is noted that where the developer plans to utilize the roadway for their encroachment the developer is responsible to clear snow from the street side of the jersey barriers refer to section 8.2 below.

7.6: Storm Water Management

During construction, nearby catch basins may be fitted with filter fabric to prevent debris from entering the storm system, the developer will maintain and periodically clean the filter fabric. Stormwater collected inside the project site will be directed to temporary stormwater settling ponds situated within the building footprint to allow clean water to be pumped into the existing public stormwater system in accordance with HRM By-law W-101 complete with appropriate fees to Halifax Water (HW). Sediment ponds may be shifted and positioned as desired by the site contractor during site work however will generally be placed in localized low points within the building footprint.

7.7: Noise, Dust and Emission Control

The contractor will at all time adhere to the HRM Noise Bylaw (N-200). No work will take place on the project site outside those hours identified in section 2 of this report.

Dust mitigation for this project will be achieved using rock pads for trucks exiting the site. A water truck and sweeper truck will also be utilized to help prevent dust from becoming airborne and, when required, calcium may need to be used to mitigate dust migration. Additionally, mesh on the inside of the fencing will help to contain any airborne dust inside the site.

Breaking of rock may occur and rock faces cleared to form a wall. Mesh will be used on the inside of all construction fencing to mitigate dust control.

All construction vehicles will be required to use the loading area for parking and idling to keep exhaust emissions within the construction zone. Vehicles will be staged so that idling will not occur for more than 3 minutes at a time.

As indicated above, all work shall be completed in accordance with the HRM Noise By-Law.

7.8: Rodent Control

Rodent movement increases during construction activities. The owner will engage a rodent control company, to utilize the established Rodent Control Plan (RCP) to help mitigate rodent movement prior to and during construction. The RCP applies to all project phases with the goal of preventing movement of rodents off-site to find safe refuge in

adjacent areas. The RCP will consist of a baiting and monitoring program. Bait stations (traps) will be placed as outlined in the NPMA Pest Management Standards for Food Processing & Handling Facilities.

The RCP will be engaged two weeks prior to the commencement of site excavation to help to lower the number of active rodents in the project area. Bait stations will be positioned along existing buildings and fence lines prior to excavation. Bait stations will be positioned along the edges of the project and secured in place using wooden stakes (for open sodded and dirt locations), weighted patio stones (behind walls and on paved areas), and zip-ties (fixed to fences) as per typical industry standards.

Refer to the appendix for a copy of the Rodent Control Plan.

Section 8: Site Protection & Hoarding

8.1: Barriers and Fences

The encroachment will be delineated by construction fencing that will be anchored to adjacent concrete F-type jersey barriers via walkthrough supports that span the pedestrian route. Fencing structure will be 1.8m or 6ft as per the noted administrative order and covered with a black dust control mesh of high quality which will extend a minimum 3m from the public right-of-way. This screening is described in the appendix and will block passersby or tourists view of the construction site. Construction traffic will utilize the proposed gates, gate will not be screened for safety reasons.

All fencing along private sidelines will have black dust control mesh covering, the hoarding will be at least 1.5m (5ft) high.

The F-type barriers and fencing that define the encroachment will adhere to the Encroachment Plan which is to scale includes dimensions and can be found in the appendix. These areas can be measured for the administering of applicable fees. Encroachment areas and fees will be based on the areas within the public right-of-way enclosed by the barriers and fencing.

Installation of F-Type concrete barriers, fencing and covering will take place during regular working hours as noted above. This work will be scheduled by the contractor after the HRM's pre-construction meeting has been held. HRM will coordinate this pre-construction meeting; the developer, contractor and traffic control company will attend this site meeting. During the process of erecting and tearing down the traffic barriers, fencing and opaque covering defining the encroachment, traffic control elements will be implemented as per the Barrier Installation Plan in the appendix. All work and any traffic interruptions will be coordinated by the contractor who will notify HRM a minimum of five (5) business days before work is scheduled to begin.

8.2: Snow removal

The developer will be responsible to remove snow and ice as required to ensure that emergency access is maintain to the project site, this includes fire hydrants. The contractor will not dump snow or ice onto adjacent property and will truck snow off site as required to prevent the unsafe build-up of snow piles.

The developer will be responsible to clear snow from the pedestrian route and from outside the jersey barriers to keep the pedestrian route and edge of the vehicle travel lane free and clear of snow and ice build up.

8.3: Gates Access & Egress

The site will be accessible through gates. These gates are the only locations that will receive equipment/materials during construction, gates will remain closed when not in use. In cases of emergencies, on-site workers will exit the project site through these gates. These gates will remain unlocked at all times when workers are on site in case of emergency allowing unrestricted emergency response units access to the site. However, gates will be locked at all times after work hours.

Various construction access gates are planned for this project. The encroachment will have two gates, stationed at the north and south ends of the encroachment. The north gate will be the main gate for building material deliveries accessing the elevator lift while the south gate will primarily be used for garbage collection. Three other gates are anticipated for the project, one on the south side off the Morris Street Extension that will align with the planned south garage entrance, while two others will be on the north side of the site. These north gates will have access from the Bishop Landing's existing service driveway via easement right-of-way; the first gate will align with the planned north garage entrance while the second near the boardwalk will provide access to the site compound.

All gates are to swing into site, remain closed when not in use and locked after hours. It is noted that the gates off the easement will be used for piling and concrete operations while the encroachment gates will be for building material delivery trucks backing into the elevator lift. Refer to the concrete delivery schematic in the appendix.

Any existing fire hydrants located adjacent to the site will remain protected from construction activities. These fire hydrants, along with the existing and proposed fire department connections (Siamese connections) will be accessible to firefighters throughout all phases of the project. Adjacent existing hydrants and fire department connections are not anticipated to be affected by construction.

8.4: Hoarding Aesthetics

The site hoarding will resemble that shown in the appendix; the developer plans to install advertisements and renderings on the fencing and apply for a partial encroachment fee reduction at a later date.

8.5: Sight Lines

Fencing and signage will be installed as per the CMP drawings such that vehicle sight lines are maintained around corners, particularly at driveway access points.

8.6: Project Information and Contacts

To encourage communication between the project team and the public, contact information will be provided on Project Information Boards; these will be posted prominently around the project site on the fencing; refer to the appendix for a copy of the Project Information Board and the Encroachment Plan for the planned locations. Refer to the signage specification within the appendix describing the required size, materials, mounting hardware, etc. of these signs.

Section 9: Lifting, Hoisting, and Crane Operations

9.1: Crane Use Overview

This project will incorporate a tower crane, this crane will be stationed within the project site and will be operated under the direct supervision of a licensed crane operator employed by the formwork contractor. The approximate location of the crane tower is shown in the appendix.

It is anticipated that the crane will be assembled and disassembled from within the hoarded area.

The crane swing will extend over neighbouring properties as shown in the Crane Swing Diagram included in the appendix. The developer will notify these property owners prior to extending the crane over their properties. Refer to the appendix for crane information.

In addition to the tower crane the elevator lift stationed on the front of the building will aid in lifting and hosting building materials to the upper levels. Concrete pump and delivery trucks will be brought to site to accommodate concrete operations these concrete trucks will be stationed off street within the project compound (see concrete delivery schematic within the appendix) and will be operated under the direct supervision of a licensed operator.

Please note at no times shall a crane lift loads over the public realm, roads, sidewalks, etc. outside the encroachment area.

9.2: Transport Canada and Nav Canada Regulations

There are two registered aerodromes in the Halifax region; Halifax International Airport and Canadian Forces Base Shearwater Airfield. According to Transport Canada regulations, the project site is outside of the lands to which regulations for these two aerodromes apply.

9.3: Aerodromes

There are several heliport approaches in the Halifax region; both Emergency Hospitals (QEII and IWK) as well as Point Pleasant Park. Given the location of the project site relative to these various approaches we understand Transport Canada notice does not apply.

Section 10: On-Site Safety and Security

10.1: Site Safety and Security Overview

The contractor will adhere to all Occupational Health & Safety requirements throughout the completion of this project. At a minimum, the following safety protocols will be utilized to further enhance site safety and security:

- a) All workers will be required to have proof of up-to-date safety training;
- a) Personal protective equipment (PPE) will be required for all personnel on site;
- b) Adequate signage will be placed outside the hoarding, which will warn of hazards that may exist;
- c) Gates will be locked and the perimeter fencing secured to provide security against public access during off work hours and will be monitored during operation;
- d) Hoarding will clearly state “No Trespassing – Construction Personnel Only” & PPE requirements will be clearly identified (e.g., “Hard Hats and Safety Footwear Must Be Worn Beyond This Point”);
- e) Regular safety inspections will be conducted to ensure suitability of hoarding and other safety devices;
- f) Emergency contact information to be prominently posted as per the Project Information Board.

10.2: Material Handling: Loading, Unloading, Delivery and Storage

The contractor will adhere to the procedures stipulated in the Haul Route Plan for delivery of materials. Delivery vehicles will use the designated gates for entry and exit. Timing of deliveries will be coordinated to have the least possible negative impact on regular traffic. The staging and delivery area will be coordinated by the delivery companies and site personnel, delivery trucks will be housed within the encroachment.

10.3: Emergency Access & Egress

The site will be accessible through gates to facilitate construction vehicle access. In cases of emergencies, on-site workers will exit the project site through these gates. These gates will remain unlocked at all times when workers are on site in case of emergency allowing unrestricted emergency response units access to the site. Gates will be locked and secured afterhours to provide security against public access during off work hour. Emergency contact information will be posted on project information boards surrounding the site, refer to the CMP plan for details.

10.4: Security Site Lighting

Security site lighting is not anticipated for this project.

10.5: Smoking Areas

On site smoking areas will not be provided as this will be a smoke-free site.

10.6: Fire Suppression Systems

Adjacent existing fire hydrants will remain outside the project area and will be protected from construction activities. These fire hydrants, along with any existing fire department connections (Siamese connections) will be accessible to firefighters throughout all phases of the project.

The proposed fire department connections are not active at this stage of the project. These are not available for fire department use until after the building's water supply lines have been installed, tested and commissioned by the water commission, similar with the fire suppression system. This system will not be active until after the building is near complete and the encroachment fencing has been removed.

Section 11: Pre-Construction Consultation & Meeting

11.1: Pre-CMP Community Consultation

Due to the current pandemic, the developer will forego the community consultation meeting. A construction notification letter will be delivered to the properties neighbouring the construction site as well as HRM staff, notifying them of the expected work with contact information for questions and feedback. As part of this notification the surrounding community and businesses will be offered to sign up for a monthly construction project notification from the development. It is understood, HRM requires a confirmation letter from the applicant confirming delivery of notification letters to affected residents. A map indicating these properties has been included in the appendix.

11.2: Project Information and Contacts

To encourage communication between the project team and the public, contact information will be provided on Project Information Boards; these will be posted prominently around the project site on the fencing; refer to the appendix for a copy of the Project Information Board and the CMP Plan for the planned locations. Information on signage size and materials is outlined in the appendix.

11.3: Preconstruction Meeting

Prior to construction the developer, contractor and traffic control company will attend a pre-construction meeting with HRM staff to review the CMP document on site. HRM's engineering technician will confirm the date and time of this meeting; and may wish to waive the requirement.

11.4: Construction Notification

Approximately five (5) business days prior to the encroachment, an additional notification will be circulated to the neighbouring properties, notifying them that work is starting on site.

Section 12: Summary

This construction management plan was prepared with the goal to minimize negative impacts to the community, pedestrians, and traffic throughout the scope of this project. This plan will be used as a minimum standard and any further safety protection required or methods to provide a more positive environment will be used throughout construction work as necessary.

Should you have any questions or comments related to this document, please contact SDMM. For all construction-related inquiries, please contact the developer, contractor, or traffic control service provider.

Regards,

Servant, Dunbrack, McKenzie & MacDonald Ltd.

Geoff MacLean, P.Eng.

Project Engineer

Z:\SDMM\35000-35999\35800\35804\CMP\35804 Construction (IFR)\1325 Lower Water St - CMP (IFR) - 35804.docx

APPENDIX

Appendix A – Encroachment Plan

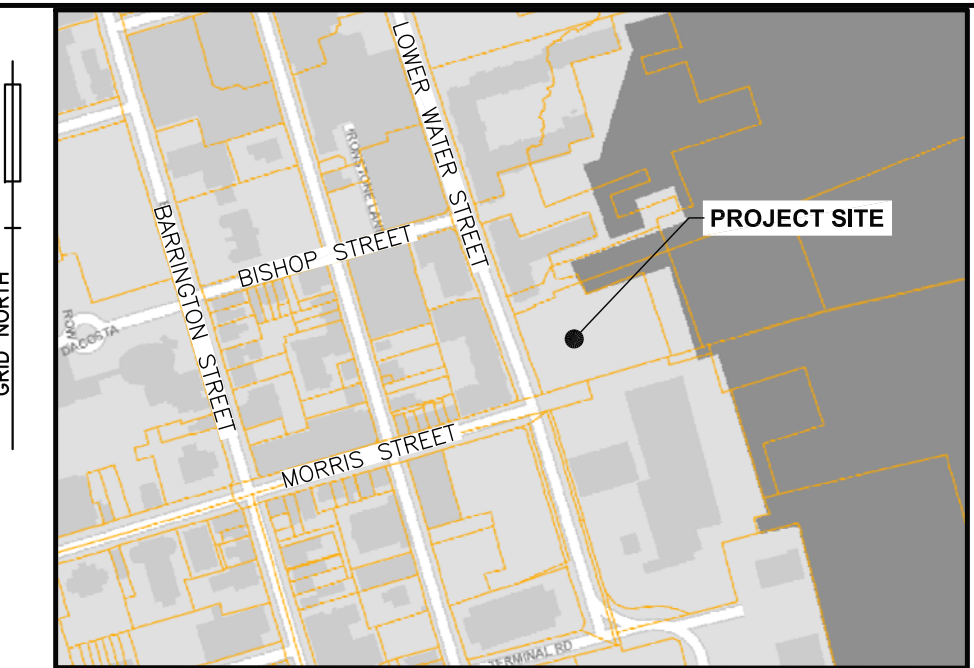

KEY PLAN

| EXISTING | | PROPOSED | |
|----------|------------------------------------|----------|------------------------------------|
| 25.0 | CONTOUR LINE | 25.0 | CONTOUR LINE |
| ●/●BF | CURB STOP/GATE/BUTTERFLY VALVE | ●/●BF | CURB STOP/GATE/BUTTERFLY VALVE |
| ⊕ | FIRE HYDRANT | ⊕ | FIRE HYDRANT |
| ⊕ | CONCRETE THRUST BLOCK | ⊕ | CONCRETE THRUST BLOCK |
| ⊕ | SIAMESE CONNECTION | ⊕ | SIAMESE CONNECTION |
| ⊕ | CATCH BASIN/PIT | ⊕ | CATCH BASIN/PIT |
| — | CULVERT | — | CULVERT |
| ⊕ | ROCK LINING/DAM | ⊕ | ROCK LINING/DAM |
| ⊕ | ROCK WALL/RETAINING WALL | ⊕ | ROCK WALL/RETAINING WALL |
| ⊕ | POWER POLE & ANCHOR/LIGHT STANDARD | ⊕ | POWER POLE & ANCHOR/LIGHT STANDARD |
| ⊕ | TREE | ⊕ | TREE |
| ⊕ | STREET SIGN/PARKING METER | ⊕ | STREET SIGN/PARKING METER |
| 131.82 | ELEVATION/GRADE | 125.00 | ELEVATION/GRADE |
| ⊕ | TEST PIT | ⊕ | TEST PIT |
| → | DRAINAGE/SWALE FLOW DIRECTION | → | DRAINAGE/SWALE FLOW DIRECTION |
| W | WATER MAIN/SERVICE | W | WATER MAIN/SERVICE |
| SAN | SANITARY MANHOLE & PIPE | SAN | SANITARY MANHOLE & PIPE |
| STM | STORM MANHOLE & PIPE | STM | STORM MANHOLE & PIPE |
| SAN/STM | COMBINED PIPE | SAN/STM | COMBINED PIPE |
| GAS | GAS LINE | GAS | GAS LINE |
| FL | 100YR. FLOOD LIMIT | FL | 100YR. FLOOD LIMIT |
| — | GUARD RAIL | — | GUARD RAIL |
| — | UNDERGROUND CONDUIT | — | UNDERGROUND CONDUIT |
| — | OVERHEAD WIRES | — | OVERHEAD WIRES |
| — | PROPERTY LINE/BOUNDARY | — | PROPERTY LINE/BOUNDARY |
| — | FENCE | — | FENCE |
| — | BUILDING | — | BUILDING |
| — | TOP OF SLOPE | — | TOP OF SLOPE |
| — | TOE OF SLOPE | — | TOE OF SLOPE |
| — | TREELINE | — | TREELINE |
| — | LIMITS OF DISTURBANCE | — | LIMITS OF DISTURBANCE |
| — | TACTILE PEDESTRIAN PLATES | — | TACTILE PEDESTRIAN PLATES |
| — | PROJECT SAFETY SIGNAGE | — | PROJECT SAFETY SIGNAGE |
| — | ORANGE SAWHORSE BARRICADE | — | ORANGE SAWHORSE BARRICADE |

NOTES

1. THIS PLAN IS IN METRIC.

| No. | YY/MM/DD | Revision | Description | App'd |
|-----|----------|----------|-------------------|-------|
| 0 | 21/02/10 | | ISSUED FOR REVIEW | |

SDMM
 Servant, Dunbrack, McKenzie & MacDonald Ltd.
 NOVA SCOTIA LAND SURVEYORS & CONSULTING ENGINEERS

36 OLAND CRESCENT
 BAYERS LAKE BUSINESS PARK
 HALIFAX, NS B5S 1C6

PHONE: (902) 455-1537
 FAX: (902) 455-8479
 WEB: www.sdmm.co

CUNARD BUILDING
 1325 LOWER WATER STREET
 HALIFAX, NOVA SCOTIA

ENCROACHMENT PLAN

| | | |
|------------------|-------------|--------------------------|
| Date | Drawn | Project No. |
| FEBRUARY 8, 2021 | D. ANDERSON | FILE NO. 1-1-144 (35804) |
| Scale | Engineer | Plan No. |
| 1:200 | G. MACLEAN | 16-2481-0 |
| Reference | Approved | Drawing Name |
| | G. MACLEAN | R1 |
| Surveyed | Sheet | |

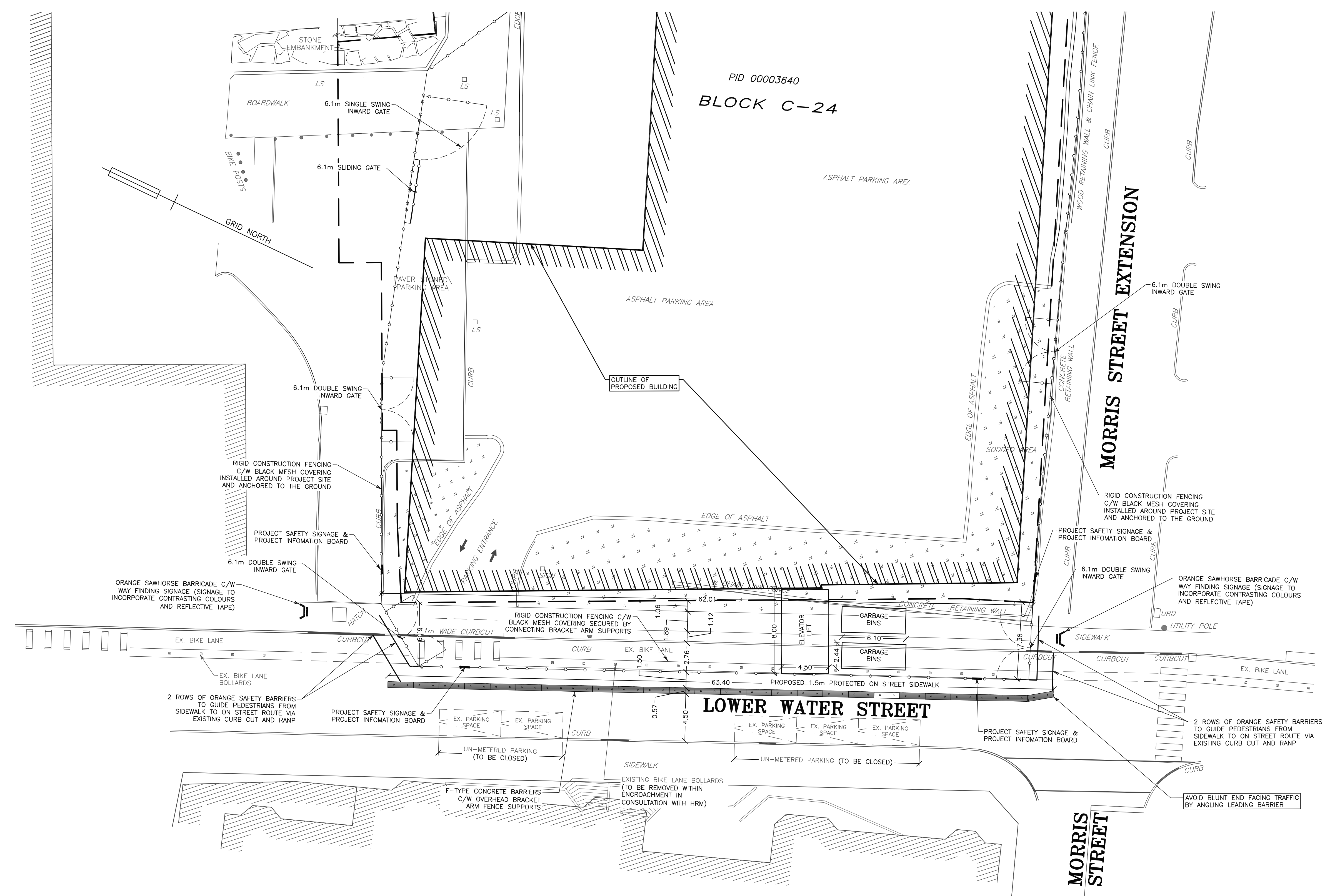

Appendix B – Traffic Control Plans (TCP)

- B1 - Encroachment Signage TCP
- B2 - Barrier Installation & Removal TCP
- B3 - Concrete Delivery TCP
- B4a - Elevator Installation TCP (Page 1 of 2)
- B4b - Elevator Installation TCP (Page 2 of 2)
- B5a - Service Installation TCP (Page 1 of 2)
- B5b - Service Installation TCP (Page 2 of 2)

Encroachment Signage Plan

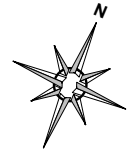

Date: 2021-02-17 Author: Norman Bussmann, TWS, Frontline Traffic Services, 902-817-3364 Project: Cunard Building
 Contrator: SDMM Contact: Geoff Maclean, 902 789-6374

Comments:
 Not to Scale
 Encroachment Signage Plan
 See Pedestrian Management Plan for sidewalk closure details.

| Legend | |
|--------|----------------|
| | F-type Barrier |
| | Gate |
| | Site Fencing |

| | | | | |
|-----|------------------------|--------|--------|-------|
| V | Speed Zone, km/h | 50 | 60-70 | 80-90 |
| A | Sign Spacing (m) | 50 | 100 | 150 |
| L | Transition Taper (m) | 30 | 60 | 120 |
| L/2 | Termination Taper (m) | 15 | 30 | 60 |
| D | Delineator Spacing (m) | 5 | 5 | 10 |
| B | Buffer Area | Note 2 | Note 2 | 30m |

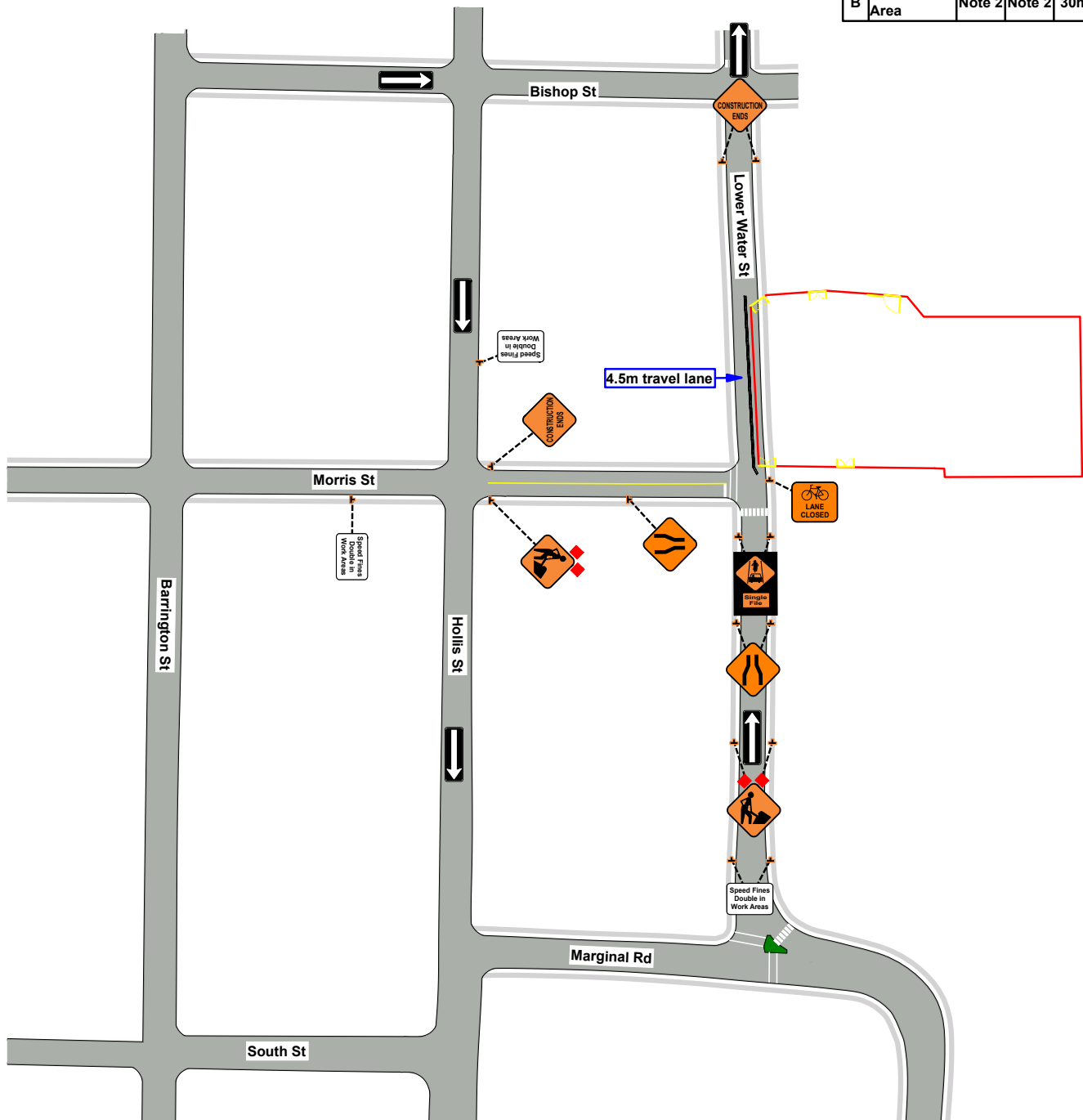

Barrier Installation and Removal Plan

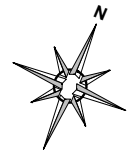

Date: 2021-02-17 Author: Norman Bussmann, TWS, Frontline Traffic Services, 902-817-3364 Project: Cunard Building
 Contrator: SDMM Contact: Geoff Maclean, 902 789-6374

Comments:
 Not to Scale
 Barrier Installation and Removal Plan
 Application Guide C22
 See Pedestrian Management Plan for sidewalk closure details.

| Legend | |
|--------|----------------|
| | Cone |
| | F-type Barrier |
| | Gate |
| | Site Fencing |
| | Work Area |

| | | | | |
|-----|------------------------|--------|--------|-------|
| V | Speed Zone, km/h | 50 | 60-70 | 80-90 |
| A | Sign Spacing (m) | 50 | 100 | 150 |
| L | Transition Taper (m) | 30 | 60 | 120 |
| L/2 | Termination Taper (m) | 15 | 30 | 60 |
| D | Delineator Spacing (m) | 5 | 5 | 10 |
| B | Buffer Area | Note 2 | Note 2 | 30m |

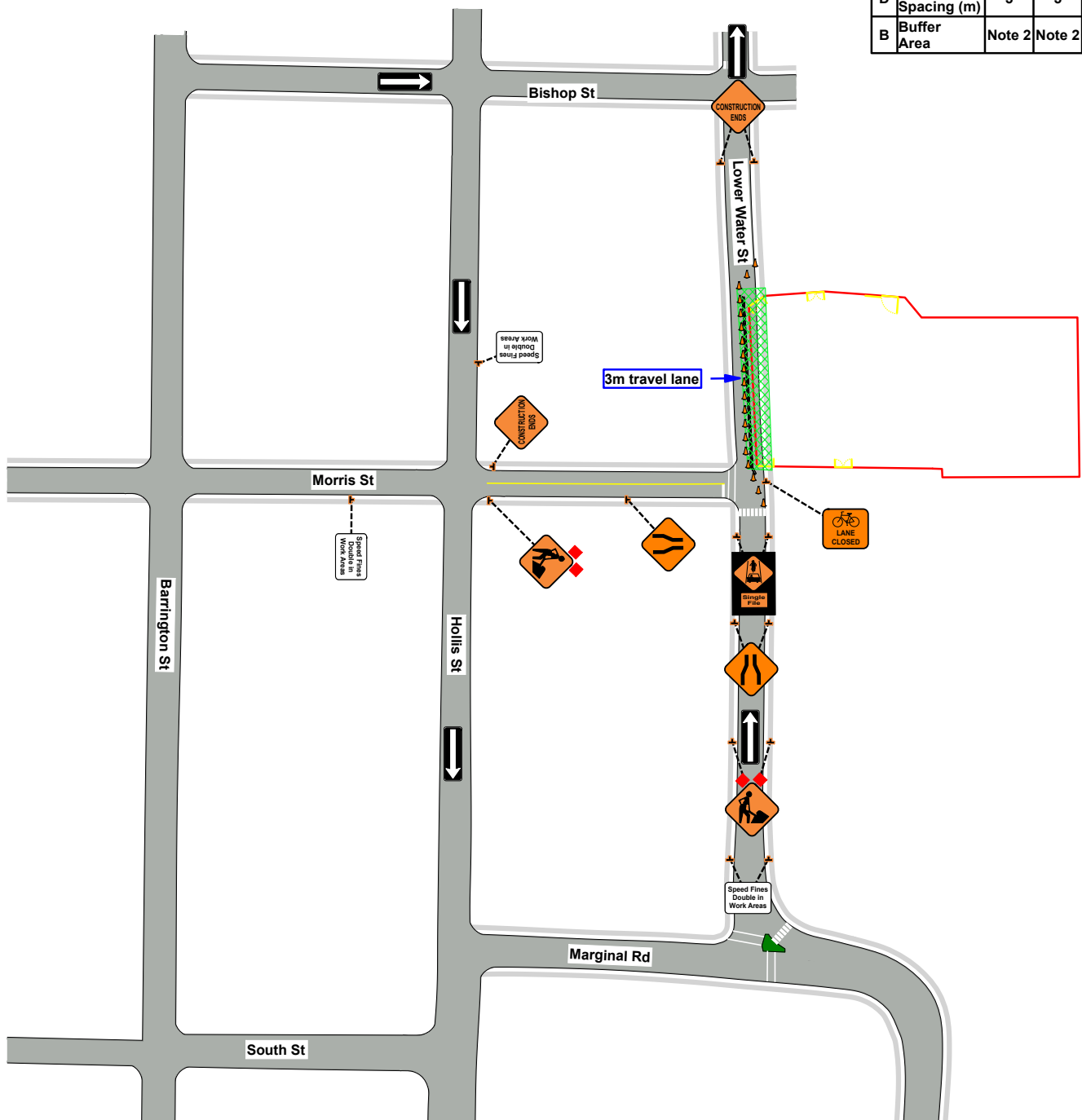

Concrete Delivery Plan

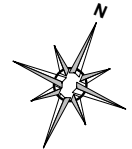

Date: 2021-02-17 Author: Norman Bussmann, TWS, Frontline Traffic Services, 902-817-3364 Project: Cunard Building
 Contrator: SDMM Contact: Geoff Maclean, 902 789-6374

Comments:

Not to Scale
 Concrete Delivery Plan
 Application Guide C33
 TC-21 to be added to Encroachment Signage to allow for short holds of traffic while trucks backing into site

| Legend | |
|--------|------------------------|
| | Control Position |
| | Delivery Route Inbound |
| | F-type Barrier |
| | Gate |
| | Reversing Trucks |
| | Site Fencing |

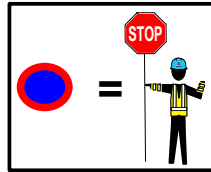

| | | | | |
|-----|------------------------|--------|--------|-------|
| V | Speed Zone, km/h | 50 | 60-70 | 80-90 |
| A | Sign Spacing (m) | 50 | 100 | 150 |
| L | Transition Taper (m) | 30 | 60 | 120 |
| L/2 | Termination Taper (m) | 15 | 30 | 60 |
| D | Delineator Spacing (m) | 5 | 5 | 10 |
| B | Buffer Area | Note 2 | Note 2 | 30m |

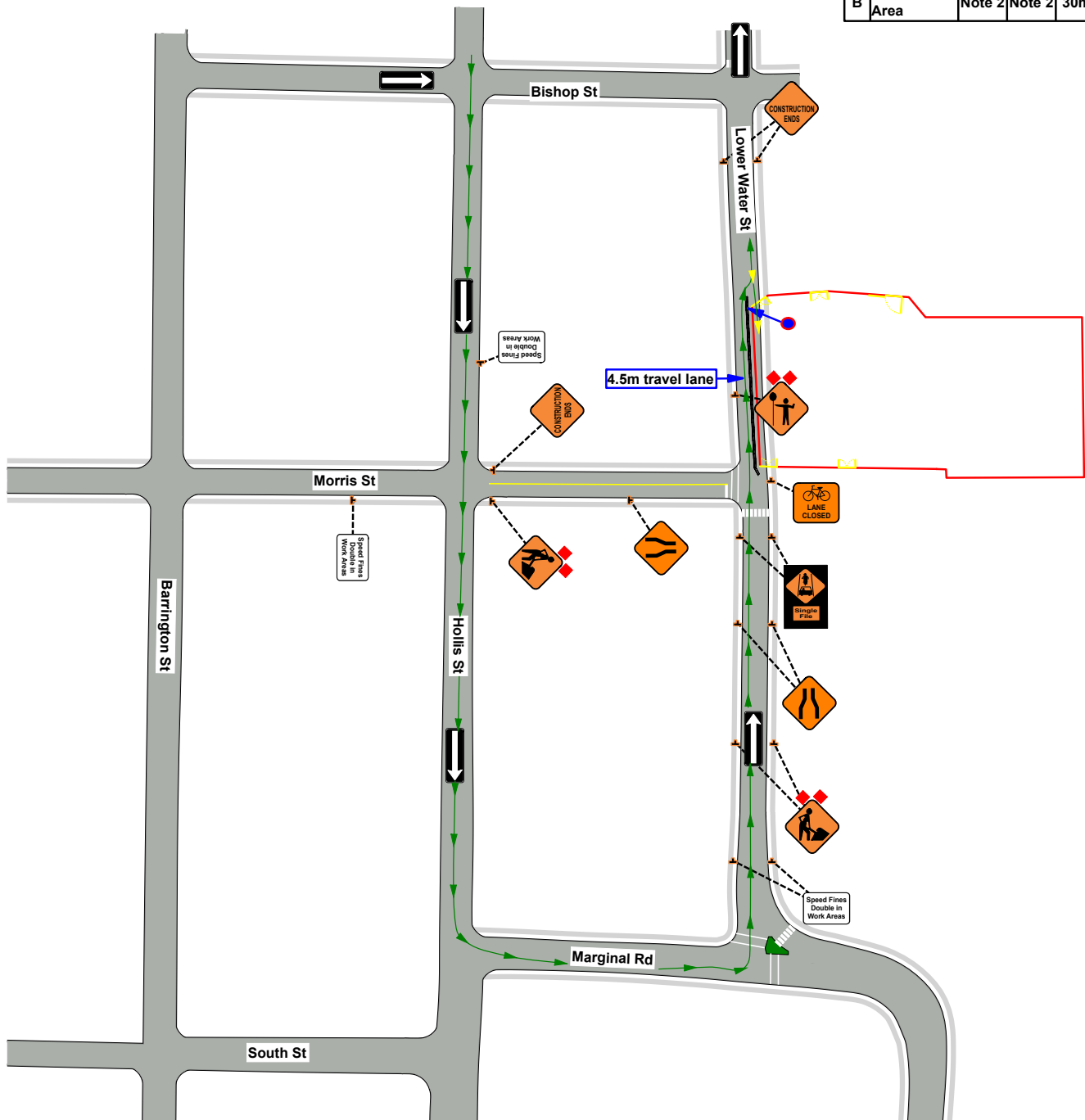

Elevator Installation Plan

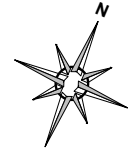

Date: 2021-02-17 Author: Norman Bussmann, TWS, Frontline Traffic Services, 902-817-3364 Project: Cunard Building
 Contractor: SDMM Contact: Geoff Maclean, 902 789-6374

Comments:

Not to Scale
 Application Guide C114
 Elevator Installation and Removal Plan
 See Pedestrian Management Plan 2 for sidewalk closure details

| Legend | | | |
|--------|------------------------|--|--|
| | Barrel | | |
| | Barricade Supervisor | | |
| | F-type Barrier | | |
| | Gate | | |
| | Site Fencing | | |
| | Traffic Control Person | | |
| | Work Area | | |

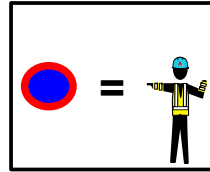
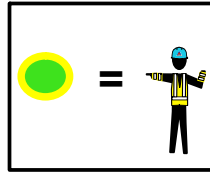

| | | | | |
|-----|------------------------|--------|--------|-------|
| V | Speed Zone, km/h | 50 | 60-70 | 80-90 |
| A | Sign Spacing (m) | 50 | 100 | 150 |
| L | Transition Taper (m) | 30 | 60 | 120 |
| L/2 | Termination Taper (m) | 15 | 30 | 60 |
| D | Delineator Spacing (m) | 5 | 5 | 10 |
| B | Buffer Area | Note 2 | Note 2 | 30m |

Custom Signage to be posted at locations shown.

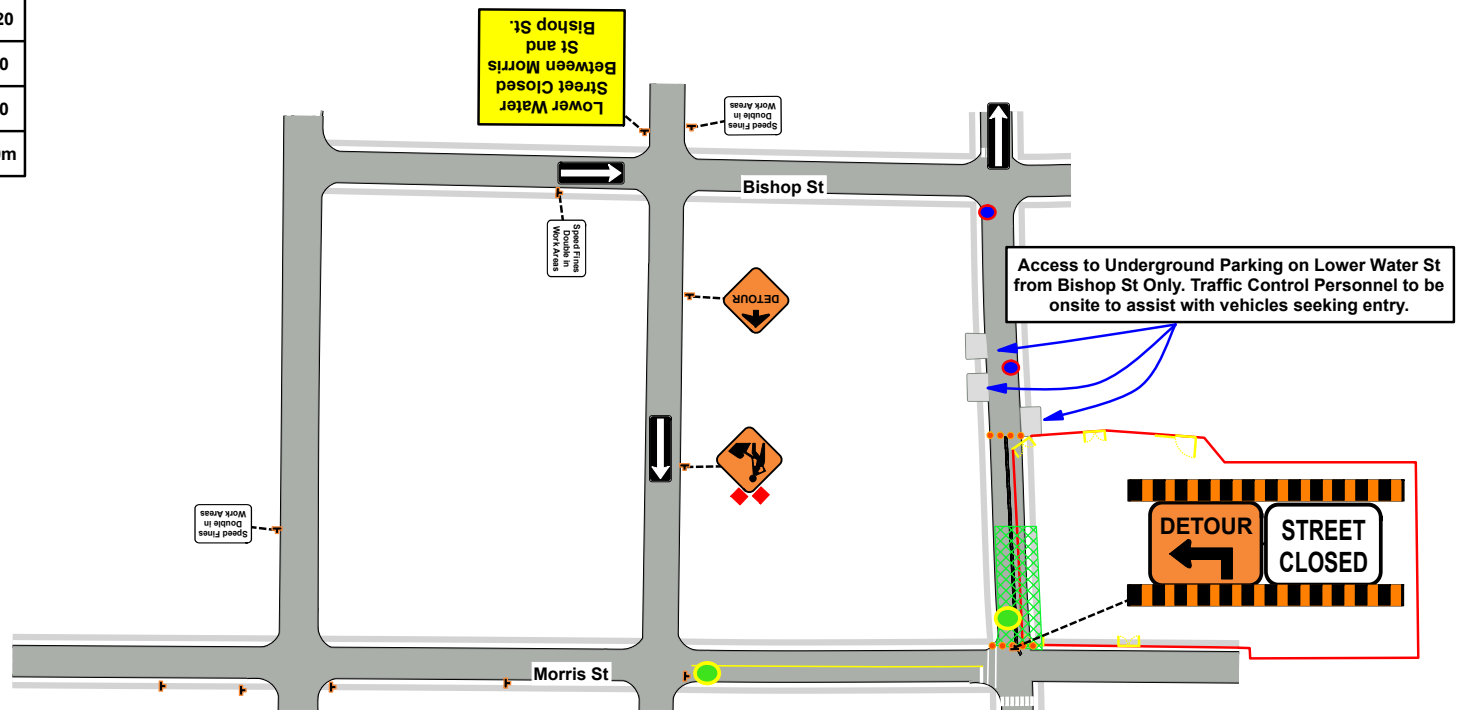

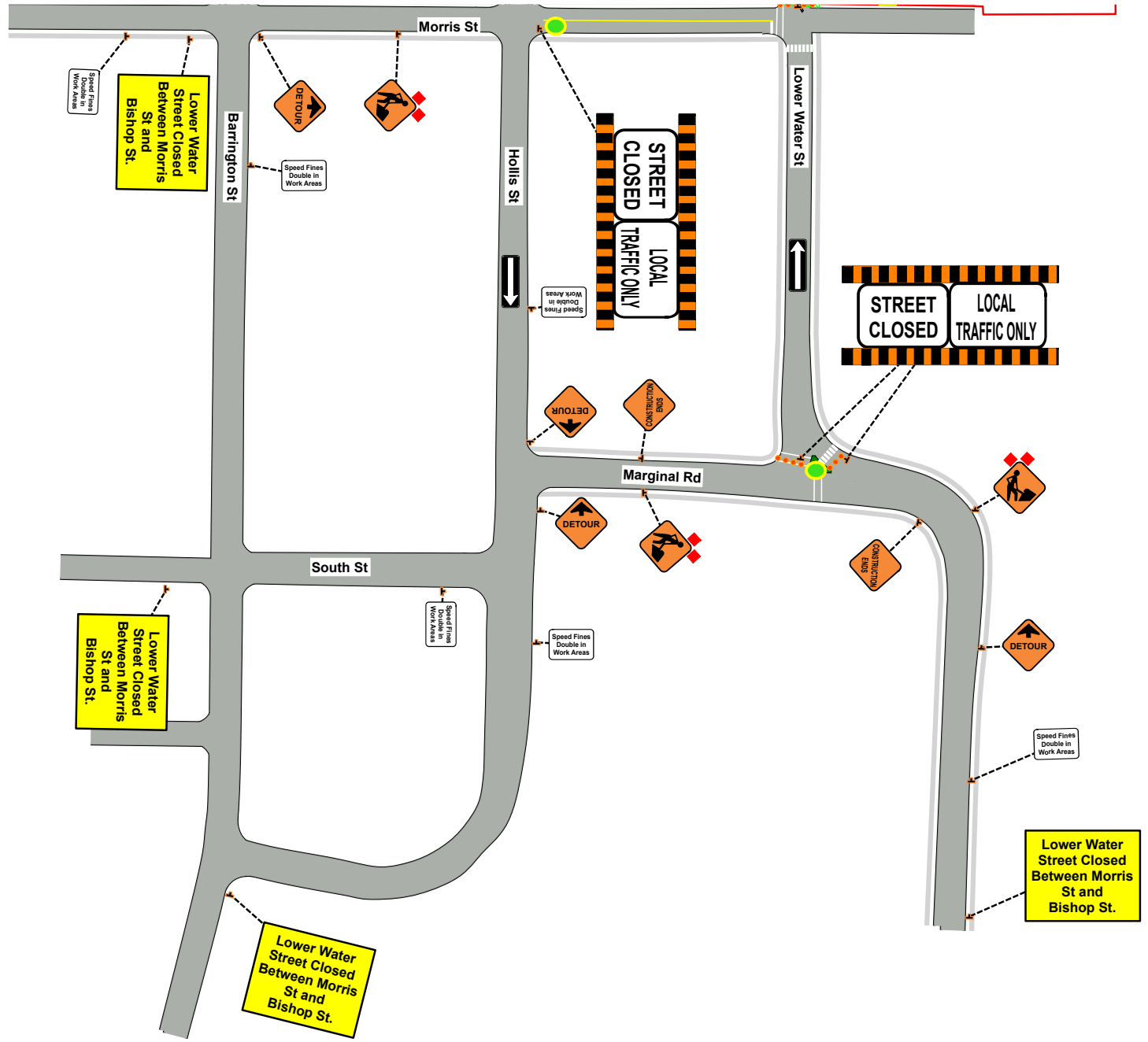

Service Installation Plan



Date: 2021-02-17 Author: Norman Bussmann, TWS, Frontline Traffic Services, 902-817-3364 Project: Cunard Building
 Contractor: SDMM Contact: Geoff Maclean, 902 789-6374

Comments:

Not to Scale
 Application Guide C114
 Service Installation Plan
 See Pedestrian Management Plan 2 for sidewalk closure details

Legend

-  Barrel
-  Barricade Supervisor
-  F-type Barrier
-  Gate
-  Site Fencing
-  Traffic Control Person
-  Work Area

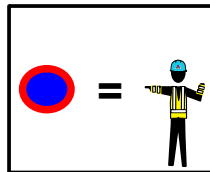
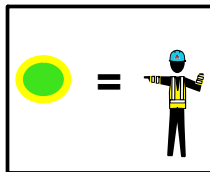

| | | | | |
|-----|------------------------|--------|--------|-------|
| V | Speed Zone, km/h | 50 | 60-70 | 80-90 |
| A | Sign Spacing (m) | 50 | 100 | 150 |
| L | Transition Taper (m) | 30 | 60 | 120 |
| L/2 | Termination Taper (m) | 15 | 30 | 60 |
| D | Delineator Spacing (m) | 5 | 5 | 10 |
| B | Buffer Area | Note 2 | Note 2 | 30m |

Custom Signage to be posted at locations shown.

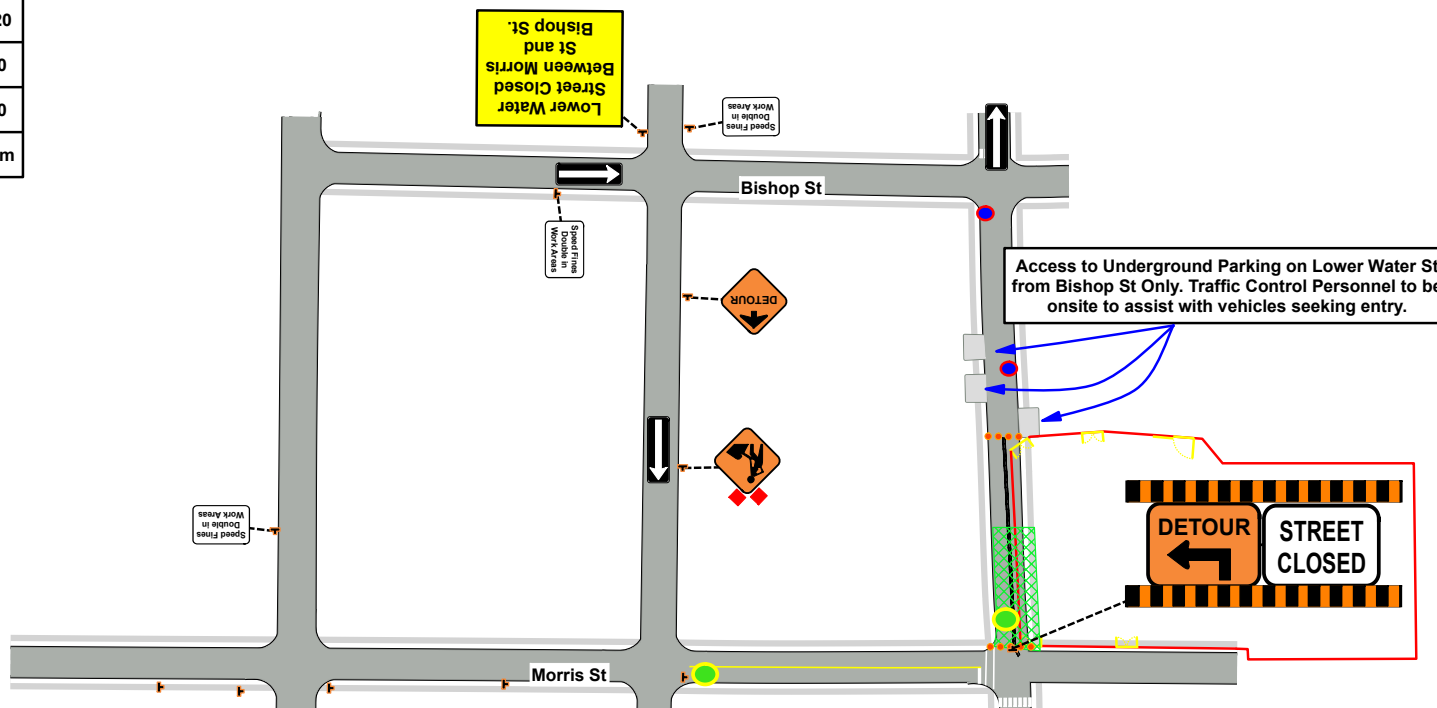

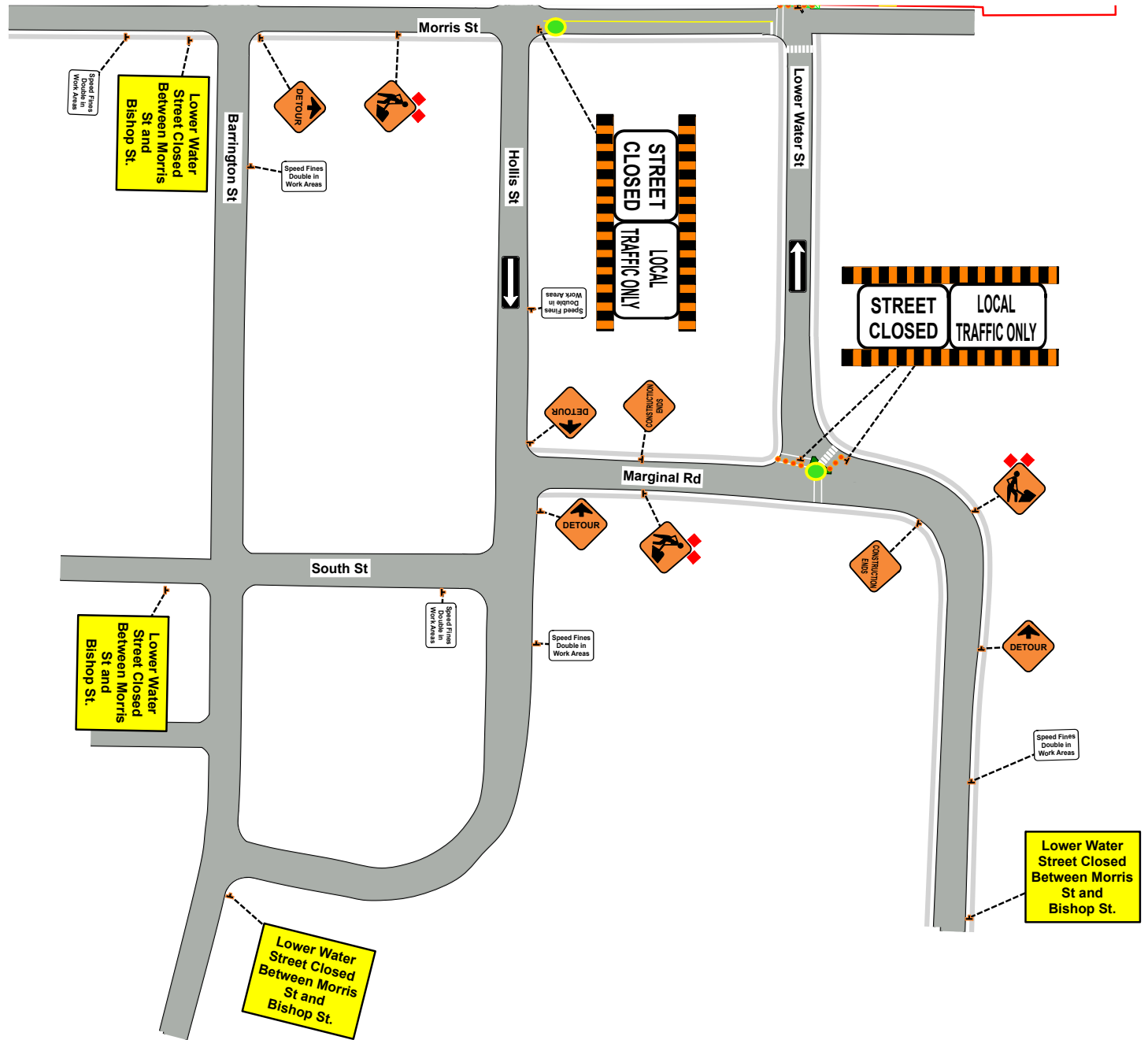

Appendix C – Haul Route Plan

Haul Route Plan



Date: 2021-02-17 Author: Norman Bussmann, TWS, Frontline Traffic Services, 902-817-3364 Project: Cunard Building
 Contrator: SDMM Contact: Geoff Maclean, 902 789-6374

Comments:
 Not to Scale
 Haul Route Plan
 Inbound via Hollis St to Marginal Rd to Lower Water St
 Outbound via Lower Water St to Upper Water St to Barrington St

| Legend | |
|--------|---------------------|
| | F-type Barrier |
| | Gate |
| | Haul Route Inbound |
| | Haul Route Outbound |
| | Site Fencing |

| | | | | |
|-----|------------------------|--------|--------|-------|
| V | Speed Zone, km/h | 50 | 60-70 | 80-90 |
| A | Sign Spacing (m) | 50 | 100 | 150 |
| L | Transition Taper (m) | 30 | 60 | 120 |
| L/2 | Termination Taper (m) | 15 | 30 | 60 |
| D | Delineator Spacing (m) | 5 | 5 | 10 |
| B | Buffer Area | Note 2 | Note 2 | 30m |

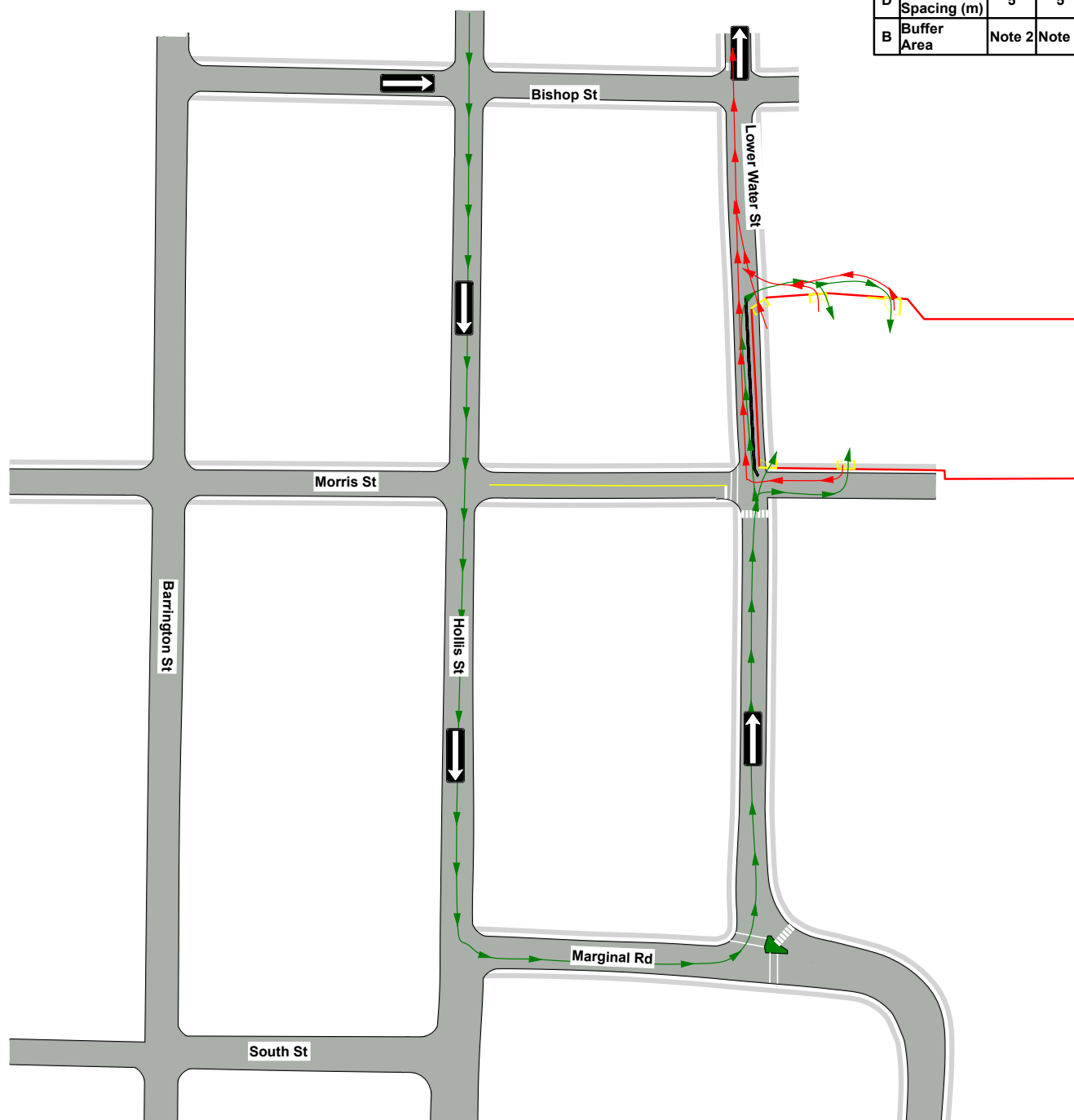

Appendix D – Pedestrian Management Plan (PMP)

- D1 - PMP 1 - Rerouted Pedestrian Route
- D2 - PMP 2 - Closed Pedestrian Route

Pedestrian Management Plan (PMP1)

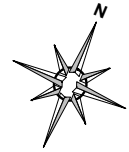

Date: 2021-02-17 Author: Norman Bussmann, TWS, Frontline Traffic Services, 902-817-3364 Project: Cunard Building
 Contrator: SDMM Contact: Geoff Maclean, 902 789-6374

Comments:
 Not to Scale
 Pedestrian Management Plan
 For Long term closure of sidewalk and use of temporary walkway

| Legend | |
|--------|------------------|
| | F-type Barrier |
| | Gate |
| | Pedestrian Route |
| | Site Fencing |

| | | | | |
|-----|------------------------|--------|--------|-------|
| V | Speed Zone, km/h | 50 | 60-70 | 80-90 |
| A | Sign Spacing (m) | 50 | 100 | 150 |
| L | Transition Taper (m) | 30 | 60 | 120 |
| L/2 | Termination Taper (m) | 15 | 30 | 60 |
| D | Delineator Spacing (m) | 5 | 5 | 10 |
| B | Buffer Area | Note 2 | Note 2 | 30m |

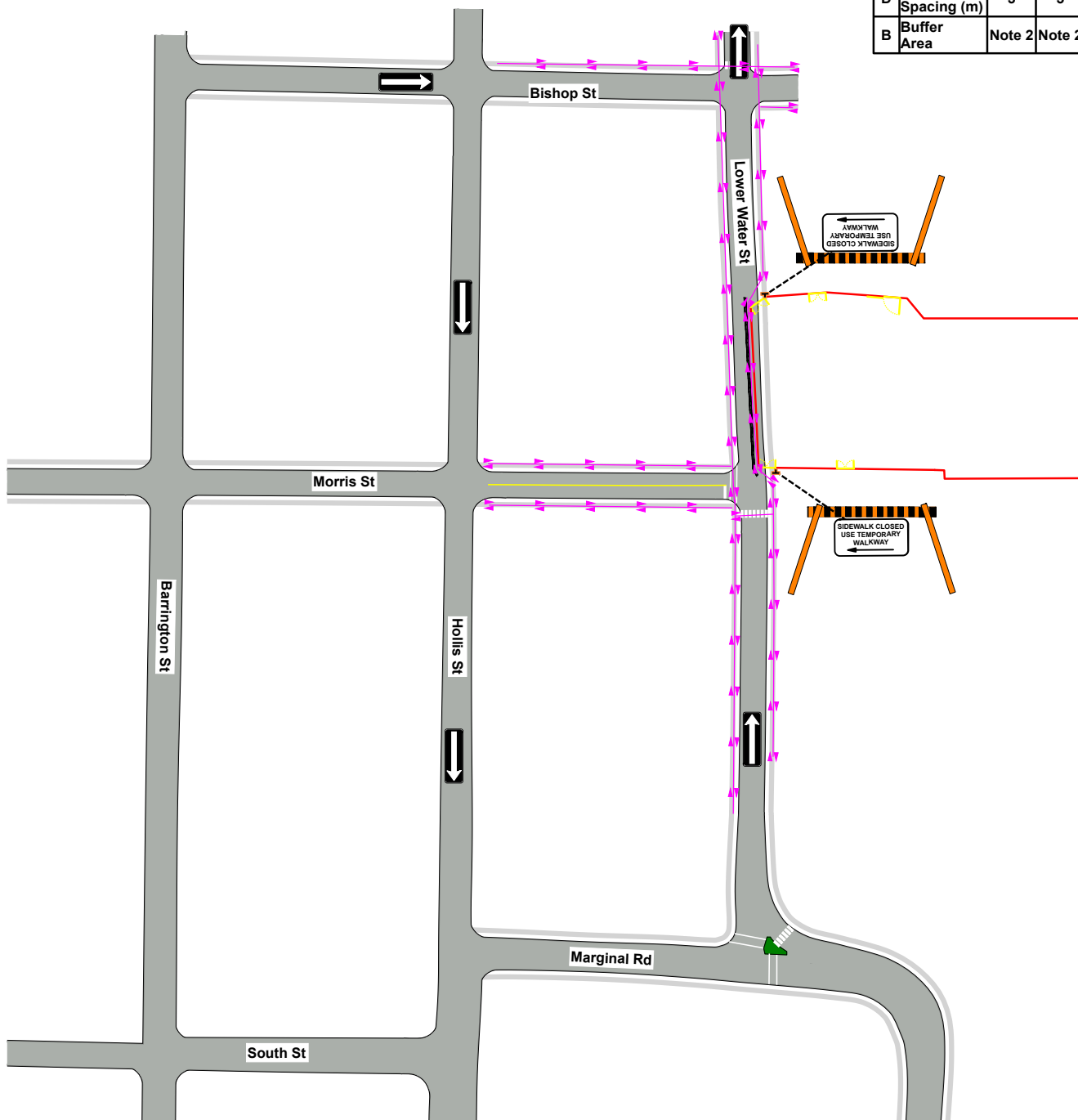

Pedestrian Management Plan 2 (PMP2)

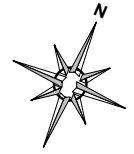

Date: 2021-02-17 Author: Norman Bussmann, TWS, Frontline Traffic Services, 902-817-3364 Project: Cunard Building
 Contrator: SDMM Contact: Geoff Maclean, 902 789-6374

Comments:
 Not to Scale
 Pedestrian Management Plan 2
 Short Duration Closure for general construction activities.

| Legend | |
|--------|------------------|
| | F-type Barrier |
| | Gate |
| | Pedestrian Route |
| | Site Fencing |

| | | | | |
|-----|------------------------|--------|--------|-------|
| V | Speed Zone, km/h | 50 | 60-70 | 80-90 |
| A | Sign Spacing (m) | 50 | 100 | 150 |
| L | Transition Taper (m) | 30 | 60 | 120 |
| L/2 | Termination Taper (m) | 15 | 30 | 60 |
| D | Delineator Spacing (m) | 5 | 5 | 10 |
| B | Buffer Area | Note 2 | Note 2 | 30m |

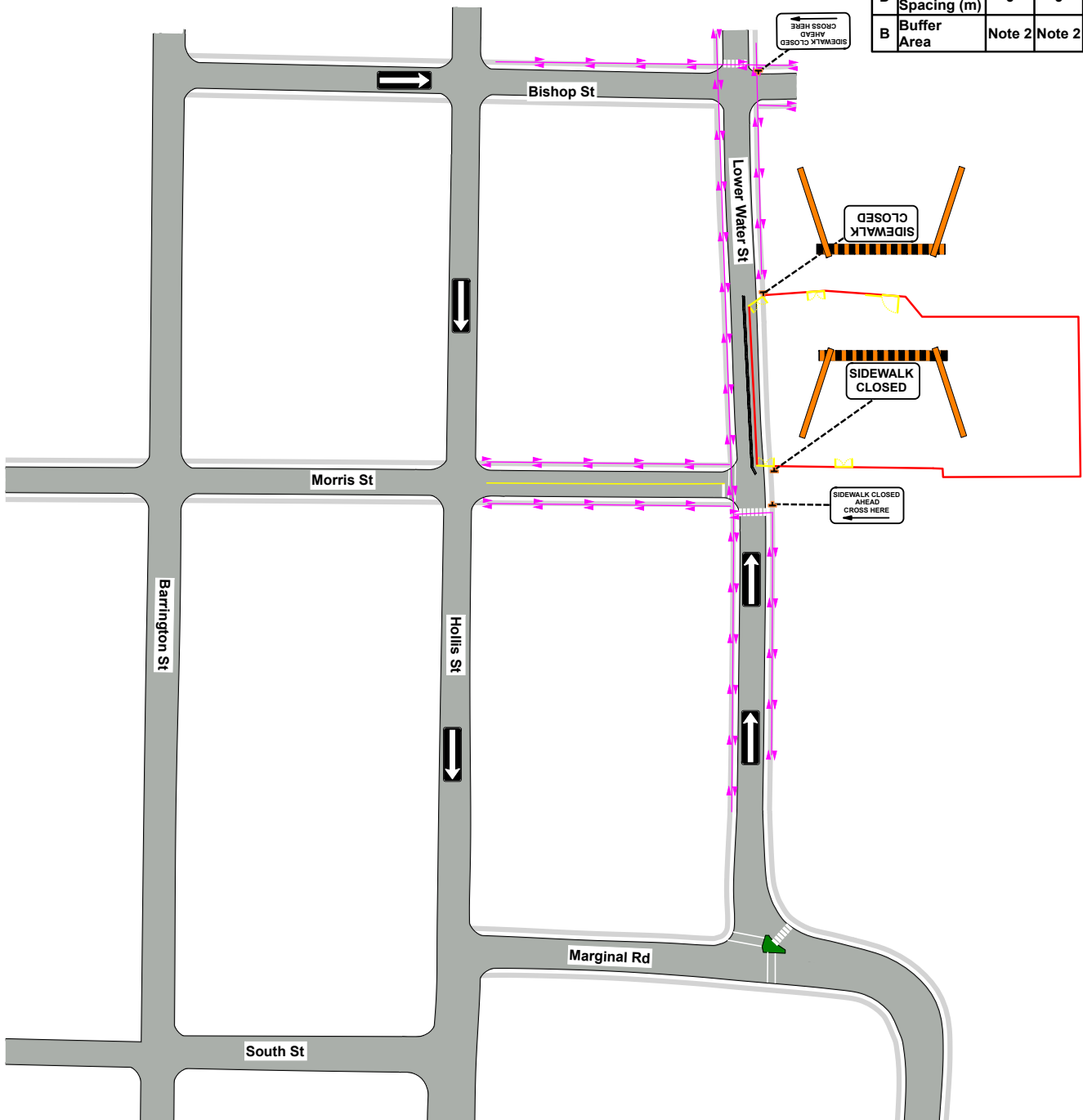

Appendix E – HRM Tree Detail

PLAN VIEW

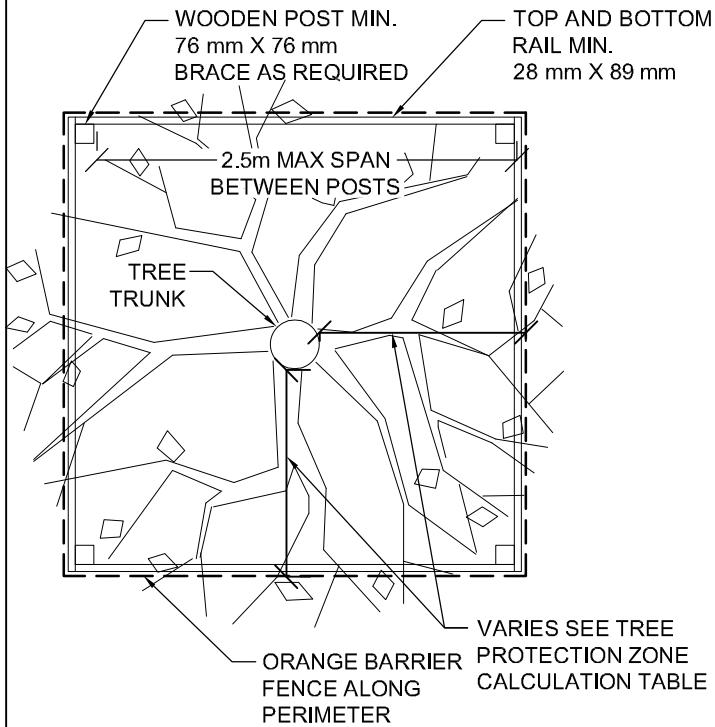

| TREE PROTECTION ZONE CALCULATION TABLE | |
|---|--|
| TRUNK DIAMETER (DBH) | MINIMUM PROTECTION DISTANCE REQUIRED (MEASURE FROM THE OUTSIDE EDGE OF TREE TRUNK) |
| 10 CM & UNDER | 1.2 METERS |
| 11 - 30 CM | 2.0 METERS |
| 31 - 40 CM | 3.4 METERS |
| 41 - 50 CM | 4.6 METERS |
| 51 - 60 CM | 6.0 METERS |
| 61 - 70 CM | 7.0 METERS |
| 71 - 80 CM | 8.0 METERS |
| >80 CM | 9.0 METERS |

NOTES:

1. WOOD POST: (MIN. 76mm WIDTH) INSTALLED TO A DEPTH OF 500mm (UNDERGROUND LOCATES REQUIRED)
2. TOP AND BOTTOM RAIL: (MIN. 38 X 89mm CONSTRUCTION, MAX. SPAN 2.5m), CROSS BRACING AS REQUIRED.
3. HEIGHT OF THE FENCE: MIN.1.2 METERS
4. NO GROUND DISTURBANCE WITHIN 1.2 METER OF THE TREE TRUNK (I.E. POST INSTALLATION)
5. POSTS SET BACK FROM SIDEWALK AND CURB: MIN 300mm
6. FENCE MATERIAL: MINIMUM ORANGE BARRIER FENCE OR METAL CHAIN LINK FENCE
7. ATTACH A SIGN ON TWO SIDES OF THE TREE "PROTECTION ZONE DO NOT REMOVE FENCE DURING CONSTRUCTION"

PROFILE VIEW

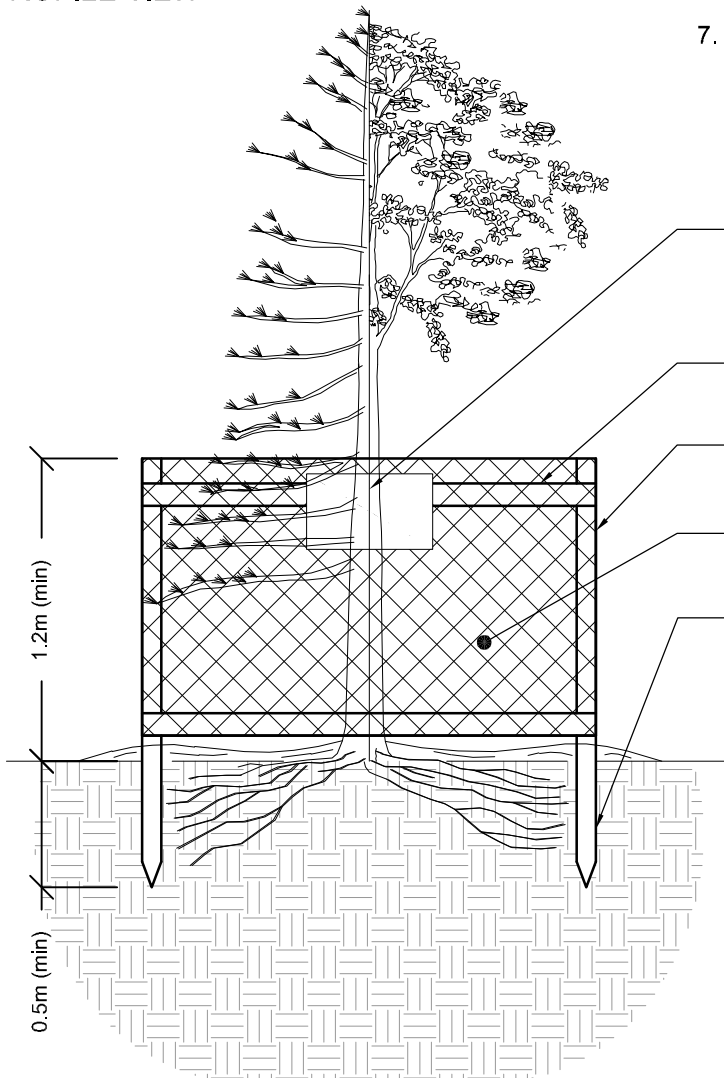

HALIFAX

STANDARD DETAIL

TREE PROTECTION ZONE & BARRIER

| | | |
|------------|------------|----------|
| DATE: 2019 | REFERENCE: | APPROVED |
| SCALE: NTS | | FIG NO: |

Appendix F – Barrier, Fence & Gates Information

Sample Barrier & Fence Details

F-shape Barrier

Approved Barrier Designs
The only pre-approved portable anti-intrusion barrier in Nova Scotia is the Portland Cement Concrete F-shape Barrier. F-shape Barriers with designs approved before 2011.01.01 must be constructed and installed copying a design certified as meeting Test Level 3 of the NCHRP Report 350 (NCHRP 350), or if the design was approved after 2011.01.01, Test Level 3 standards of the American Association of State Highway and Transportation Officials (AASHTO) Manual for Assessing Safety Hardware (MASH).

Dimensions are in mm

The technical drawing shows two views of the F-shape barrier. The front view on the left is a trapezoidal shape with a top width of 200 mm (labeled '200 Min.'). The top edge has a height of 125 mm. The bottom edge has a height of 180 mm. The total height of the barrier is 555 mm. The side view on the right is a rectangle with a width of 570 mm and a height of 810 mm. The barrier is shaded in a light olive green color.

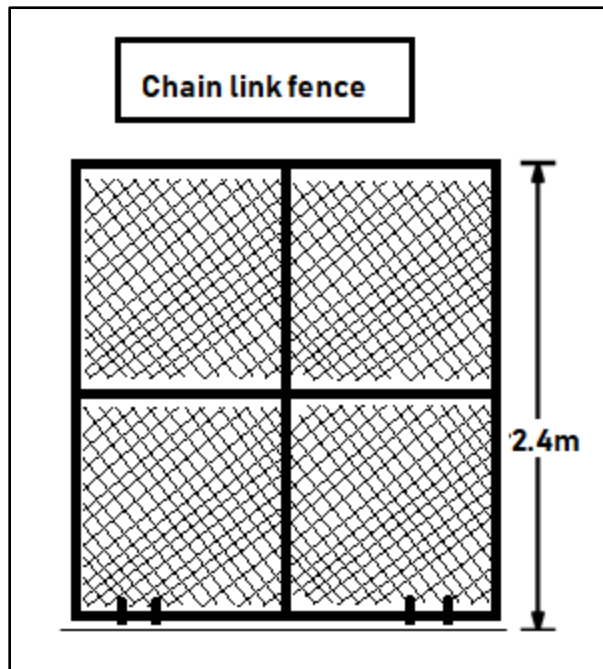

Sample Protected on street sidewalk outside of encroachment area showing concrete jersey barriers with walkthrough bracket arm attached to fence panels.



Cunard Building site fence panels complete with black mesh coverings.



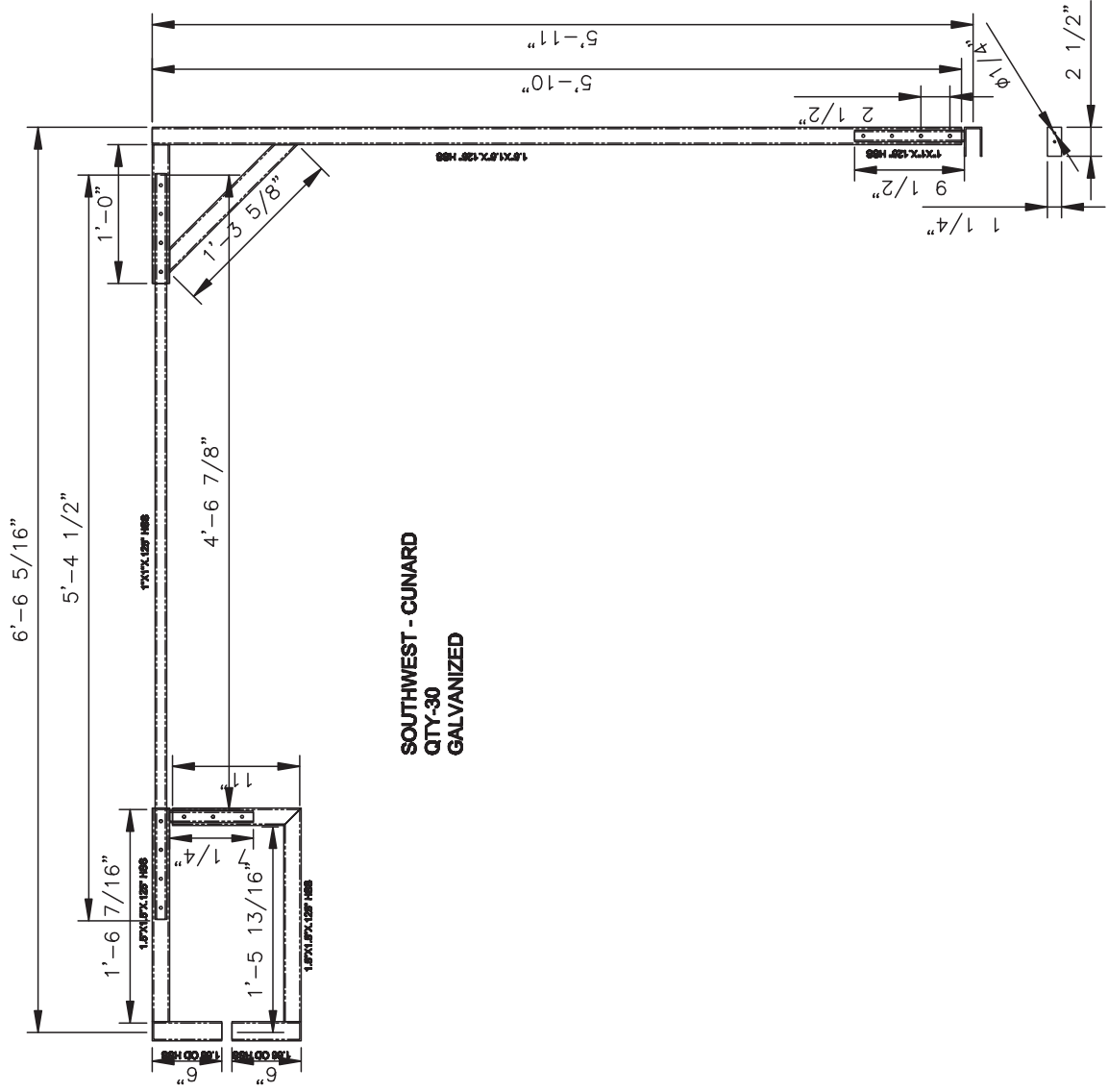

Sample Gate Detail

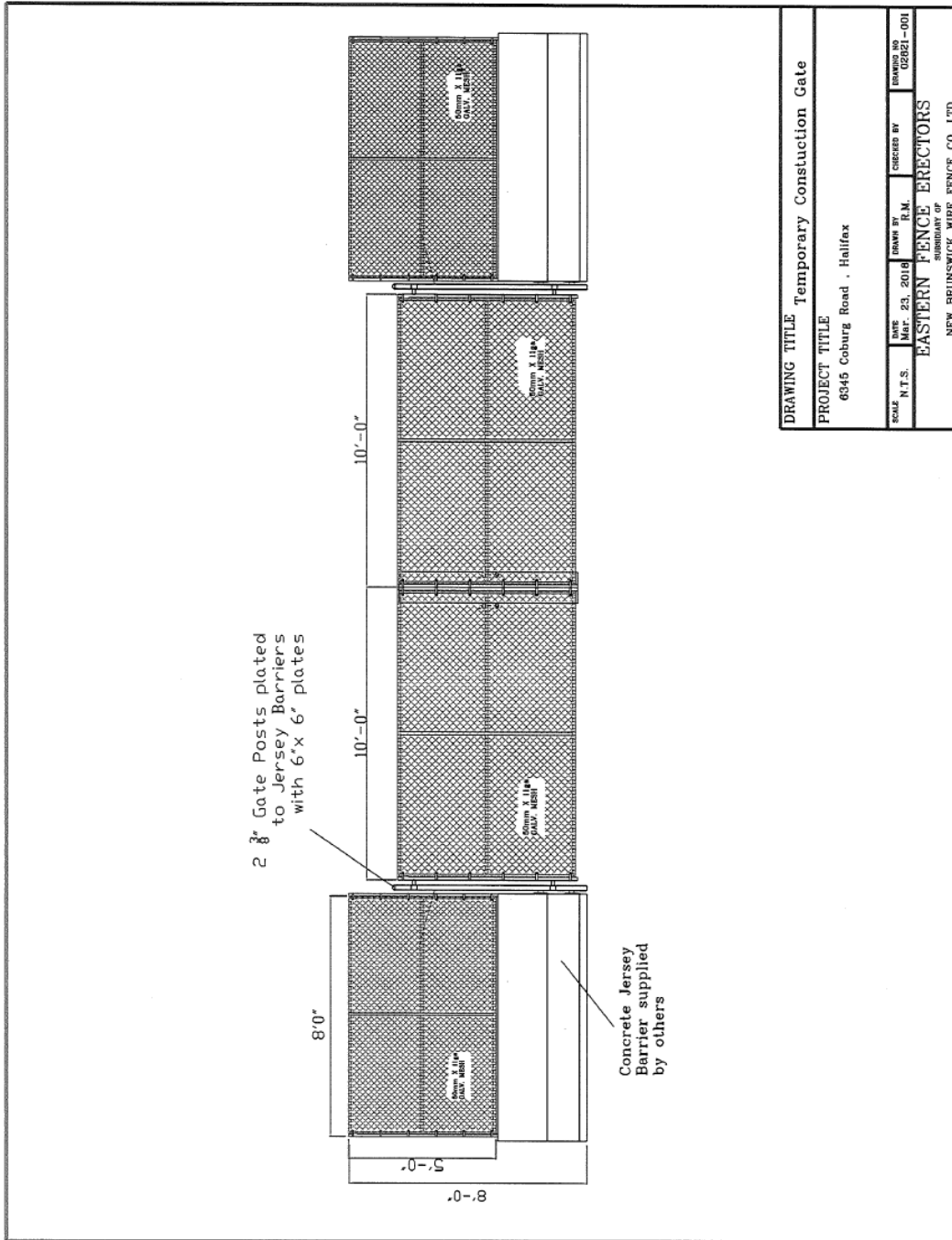

| | | | |
|---|----------------------------|-------------------------|--------------------------------|
| DRAWING TITLE Temporary Constuction Gate | | | |
| PROJECT TITLE 6345 Coburg Road , Halifax | | | |
| SCALE N.T.S. | DATE MAR 23 2018 | DRAWN BY P.M. | CHECKED BY G2021-001 |
| EASTERN FENCE ERECTORS NEW BRUNSWICK WIRE FENCE CO. LTD | | | |

Appendix G – Hoarding Information

Opaque construction hoarding material shall covering and be adequately secured to the rigid fencing that outlines the encroachment area. This covering shall be continuous such that it prevents passersby or tourist from seeing through the fencing and gates to the active construction site.

UltraMesh® Eclipse® if a 7.96 oz. which is a polyester, black-backed mesh that is used where complete opacity is required.

UltraMesh Eclipse is UV printable for project renderings and is typically used for building and fence graphic wraps. The product is available in widths of 126" and 196".

Product example is shown below with the technical data sheet on the following page.

Black Mesh



Print Banner Option



UltraMesh Eclipse is a 7.96 oz. polyester, black-backed mesh. The material is ideal for applications where complete opacity is required. UltraMesh Eclipse is UV printable and may be used for building wraps and fence graphics. Available in widths of 126 and 196 .

Material Details

| CHARACTERISTICS | TEST METHOD | METRIC | ENGLISH |
|------------------------|------------------------------|------------------------------------|-------------------------|
| Base Fabric | 100% PES | 1000D×1000D | |
| Construction | | | 12×12 |
| Total Weight | DIN53352 BS3424 Method5A | 270 +/- 20 gsm/m ² | 7.96 oz/yd ² |
| Width | | Up to 500cm | |
| Tensile Strength | DIN53352 BS3424 | Warp 1250 n/5cm Weft 1100 n/5cm | 142.75 x 130.19 lb/in |
| Tear Strength | DIN53356 BS3424 | Warp 235 N Weft 225 N | 52.8 x 50.5 lbf |
| Air Permeability | GB/T 2410-2008 | | 2649 mm/s |
| Light Transmission | GB/T 5453-1997 | | 37% |
| Temperature Resistance | DIN53357 BS3425 Method 10 | | -20°C /70°C |

Applications

| | Back-lit | Banner | Billboard | Block-out | Building Wrap | Fence Graphics | Truckside |
|--------------|----------|--------|-----------|-----------|---------------|----------------|-----------|
| Applications | | ■ | | ■ | ■ | ■ | |

Ink Printability

| Solvent | Eco Solvent | UV | Latex | Screen Printing | Dye Transfer | Dye Direct |
|---------|-------------|----|-------|-----------------|--------------|------------|
| | | ■ | | | | |

Available Sizes

| Metric (m) | English (inches) |
|------------|------------------|
| 3.20, 5.00 | 126 , 196 |

The information on physical and chemical characteristics is based upon tests believed to be reliable. The values are intended only as a source of information. A legally binding guarantee of specific properties is not to be inferred from our specifications. They are given without guaranty and do not constitute a warranty. A weight variance of +1/-2 is acceptable. The purchaser should independently determine, prior to use, the suitability of this material for his/her specific purpose. (Data represents averages and is not intended for use as a specification.)

Appendix H – Project Information Board



THE CUNARD PROJECT
1325 Lower Water Street
247 Residential Units
16 Storey Building
Commercial and Retail
space
3 Levels Parade Parking

March 2021 – July 2023

Developer:

Southwest Construction Management Limited
1475 Lower Water Street, Suite 100, Halifax, NS B3J3Z2

Contact:

Steve Seal – (902) 210-9543

Construction Manager:

Southwest Construction Management Limited
1475 Lower Water Street, Suite 100, Halifax, NS B3J3Z2

Contact:

Adam Fraser – (902) 580-5852 (24hr contact)

Contractor:

Atlantic Road Construction and Paving
6 Belmont Avenue, P.O. Box 89
Eastern Passage, NS, B3G 1M7

Contact:

Greg MacDonald - (902) 830-6411

Traffic Control:

Frontline Traffic Services
6 Belmont Avenue, P.O. Box 89, Eastern Passage, NS, B3G 1M7

Contact:

Phil Pruneau – (902) 818-5548

Rodent Control Company:

Rentokil Pest Control
51 Duke Street, Bedford, Bedford, NS

Contact:

902-835-2304

Appendix I – Project Safety Signage

Sample Safety Signage

Rules signs 2ft x 6 ft

All other signs 16-inch x 24-inch

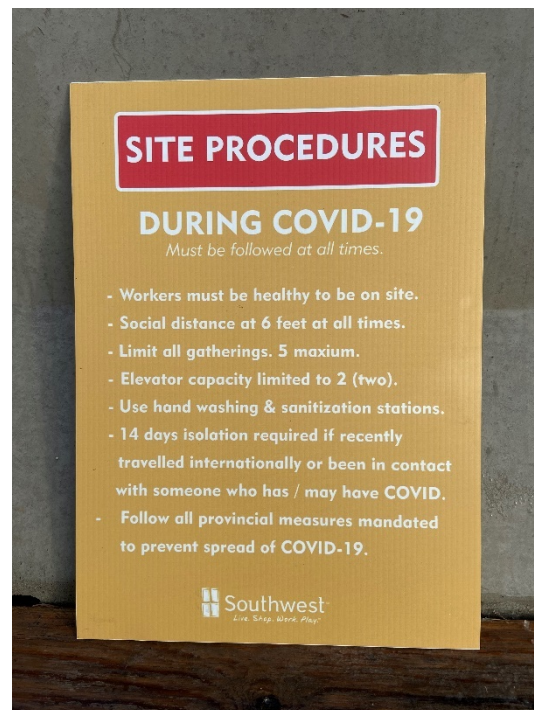



Appendix J – Project Signage Specifications

Signage Specifications: Project Signage shall;

- Be constructed of weatherproof material (corrugated plastic)
- Have high visibility contrasting colours (dark letters on white background)
- Incorporate appropriate font types (mix of upper and lower-case lettering)
- Incorporate appropriate font sizes (16mm – 51mm) such that the signage is readable from a distance (16-20m)
- Size of signage will be poster size (600mm x 900mm) or larger; to allow community members to see and read the information from a distance
- Signage may incorporate plastic grommets positioned every 300mm around the perimeter of the signage to ensure a secure signage installation
- Signage will be installed/anchored to project fencing using plastic zip-ties
- Signage will be positioned along the project site as per the encroachment plan
- Signage shall not impede traffic of pedestrian sight lines
- **Signage shall be placed on site 10 days prior to the start of the noted construction activity to ensure the passing public has had adequate time to review, adjust their travel patterns, usage of streets and or can be considered 'informed'.**

Samples



Appendix K – Sample Traffic Notification Letter



The Cunard – Multi-Unit Residential Building

DRAFT NOTIFICATION LETTER

TO WHOM IT MAY CONCERN

Date

NOTIFICATION OF TRAFFIC DISRUPTION: **Street Name**, HALIFAX, NOVA SCOTIA

This is to inform you that the to facilitate operations in association with the **** **Lower Water Street**, Multi-Unit Residential building construction work, traffic disruptions will occur on or about **DATE** with an anticipated duration of approximately **TIME**. The street will be **reduced(?)** to one lane of vehicular traffic during this time.

Should you have any questions or concerns please feel free to contact the below:

CONTACT INFORMATION

General Contractor:

Atlantic Road Construction and Paving

6 Belmont Avenue, P.O. Box 89

Eastern Passage, NS

B3G 1M7

Phone: (902) 830-6411

Should any questions arise, please feel free to contact the undersigned.

Yours Truly,

Greg MacDonald

Atlantic Road Construction and Paving

Appendix L – Vehicular and Pedestrian Hazard Assessment

Project

Date:

Location:

VEHICULAR & PEDESTRIAN HAZARD ASSESSMENT

| No. | Hazard: | Project Phase: | Vehicular Impacts: | Mitigation Methods: | Pedestrian Impacts: | Mitigation Methods: |
|-----|---|----------------|--|---|--|--|
| 1 | Excavation | Excavation | Vehicles may enter project site and fall down excavation. | Place concrete barriers along travel ways. Concrete barriers and existing curbs to prevent vehicle entry. | Pedestrians may enter project site and fall down excavation. | Place concrete barriers/rigid fencing around entire project site. |
| | | | Vehicle weight may surcharge excavation, causing excavation wall failure. | Close sidewalks & driveways adjacent to project site, moving vehicles farther away from excavation. | | |
| 2 | Rock Blasting | Excavation | Blasted rock projectiles may strike vehicles. | Close sidewalks & driveways adjacent to site, moving vehicles farther away from blasted rock. | Blasted rock projectiles may strike pedestrians. | Install solid plywood hoarding along rigid fence adjacent to blasting zone. |
| 3 | Construction Waste | All Phases | Vehicles may be struck by construction waste. | The contractor shall keep the project site and surrounding areas clean and free of construction debris. | Pedestrians may be struck by construction waste. | The contractor shall keep the project site and surrounding areas clean and free of construction debris. |
| 4 | Vehicular & Pedestrian Activities | All Phases | Drivers and pedestrians may become confused or impatient with construction activities. Pedestrians may walk in unmarked crosswalks or in vehicular travel areas. Drivers may fail to obey traffic signage. | Vehicular and pedestrian signage will be posted prominently around the project site to facilitate pedestrian movement. Notification will be sent prior to all traffic interruptions. | Drivers and pedestrians may become confused or impatient with construction activities. Pedestrians may walk in unmarked crosswalks or in vehicular travel areas. Drivers may fail to obey traffic signage. | Vehicular and pedestrian signage will be posted prominently around the project site to facilitate pedestrian movement. Notification will be sent prior to all traffic interruptions. |
| 5 | Heavy Machinery Operation | All Phases | Heavy machinery or vehicles may break down or overturn, damaging other vehicles. | The contractor shall maintain safe distances between vehicles and heavy machinery on-site. Concrete barriers will be installed to separate construction vehicles from public traffic. | Heavy machinery or vehicles may break down or overturn, injuring pedestrians. | The contractor shall maintain safe distances between pedestrians, vehicles, and heavy machinery. Rigid fences will be installed to separate construction vehicles from pedestrians. |
| | | | Heavy machinery or vehicles may overturn due to uneven terrain, damaging other vehicles. | The contractor shall maintain safe distances between vehicles and heavy machinery on-site and ensure travel routes are kept flat. | Heavy machinery or vehicles may overturn due to uneven terrain, injuring pedestrians. Pedestrians may walk on uneven terrain causing them to twist their ankles or fall. | The contractor shall maintain safe distances between pedestrians, vehicles, and heavy machinery and ensure travel routes are kept flat. |
| 6 | Construction Signage | All Phases | Construction signage may strike vehicular traffic. | Construction signage will be securely fixed to existing poles, temporary concrete sign bases, or rigid fences. | Pedestrians may walk into construction signage, including traffic signage, wayfinding signs, etc. may. | Signage will be angled in line with pedestrian routes and/or be placed at heights such that they do not pose a risk to pedestrians. |
| | | | | | Construction signage may strike pedestrians. | Construction signage will be securely fixed to existing poles, temporary concrete sign bases, or rigid fences. |
| 7 | Dangerous Materials | All Phases | Flammable, explosive, & hot materials may damage vehicles if not properly maintained & stored. | The contractor will use and store dangerous materials properly as per manufacturers' specifications. | Flammable, explosive, & hot materials may injure pedestrians if not properly maintained & stored. | The contractor will use and store dangerous materials properly as per manufacturers' specifications. |
| 8 | Hoisting Operations | Superstructure | Precast concrete panels and other items hoisted may fall from heights and damage vehicles. | Proper hoisting and lifting techniques will be used to ensure that materials do not fall from heights. F-Type concrete barriers will be installed such that loads are never suspended above the public realm. | Precast concrete panels and other items hoisted may fall from heights and injure pedestrians. | Proper hoisting and lifting techniques will be used to ensure that materials do not fall from heights. Pedestrians will be moved to opposite sides of street from the project site or onto temporary sidewalks such that loads are never suspended above the public realm. |
| 9 | Reinstatement of Public Infrastructure & Service Installation | Superstructure | Heavy equipment and hot concrete used during public infrastructure reinstatement and service installation may cause damage to vehicles. | The contractor shall maintain safe distances between vehicles and heavy machinery on-site. Concrete barriers will be installed to separate construction vehicles from public traffic during public infrastructure reinstatement and service installation. | Heavy equipment and hot concrete used during public infrastructure reinstatement may injure pedestrians. | The contractor shall maintain safe distances between pedestrians, vehicles, and heavy machinery. |
| 10 | Fallen debris | Superstructure | Debris may fall from upper stories of the new building causing damage to vehicles. | F-Type concrete barriers will be installed such that a safe distance is maintained between the building envelope and vehicular traffic. | Debris may fall from upper stories of the new building injuring pedestrians. | Construction of upper building levels will be set back from the property line/rigid fencing, this separating pedestrians from potential fallen debris. |

Appendix M – Community Consultation Records

COMMUNITY CONSULTATION MAP OVERVIEW

Project – 1325 Lower water Street

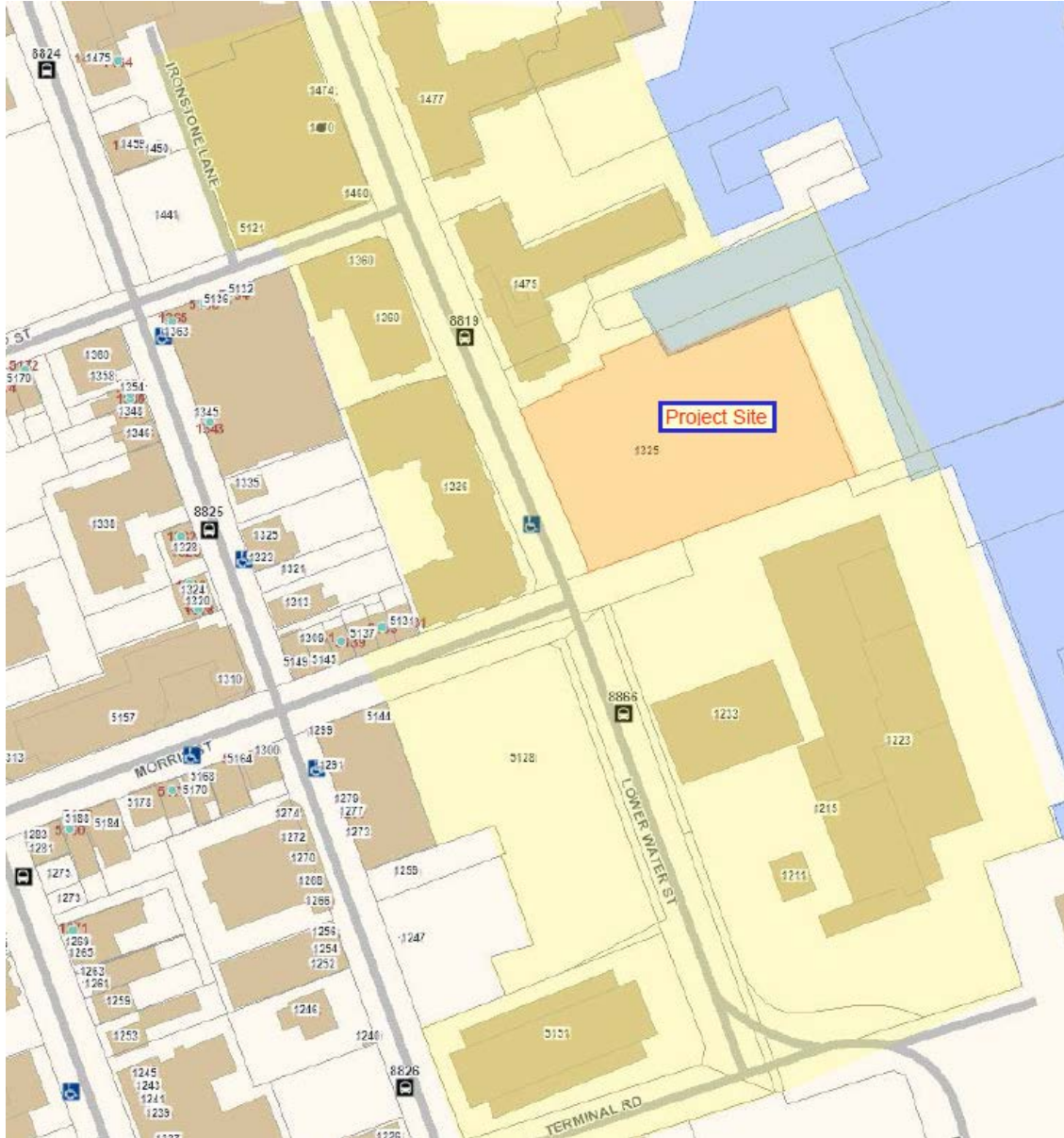

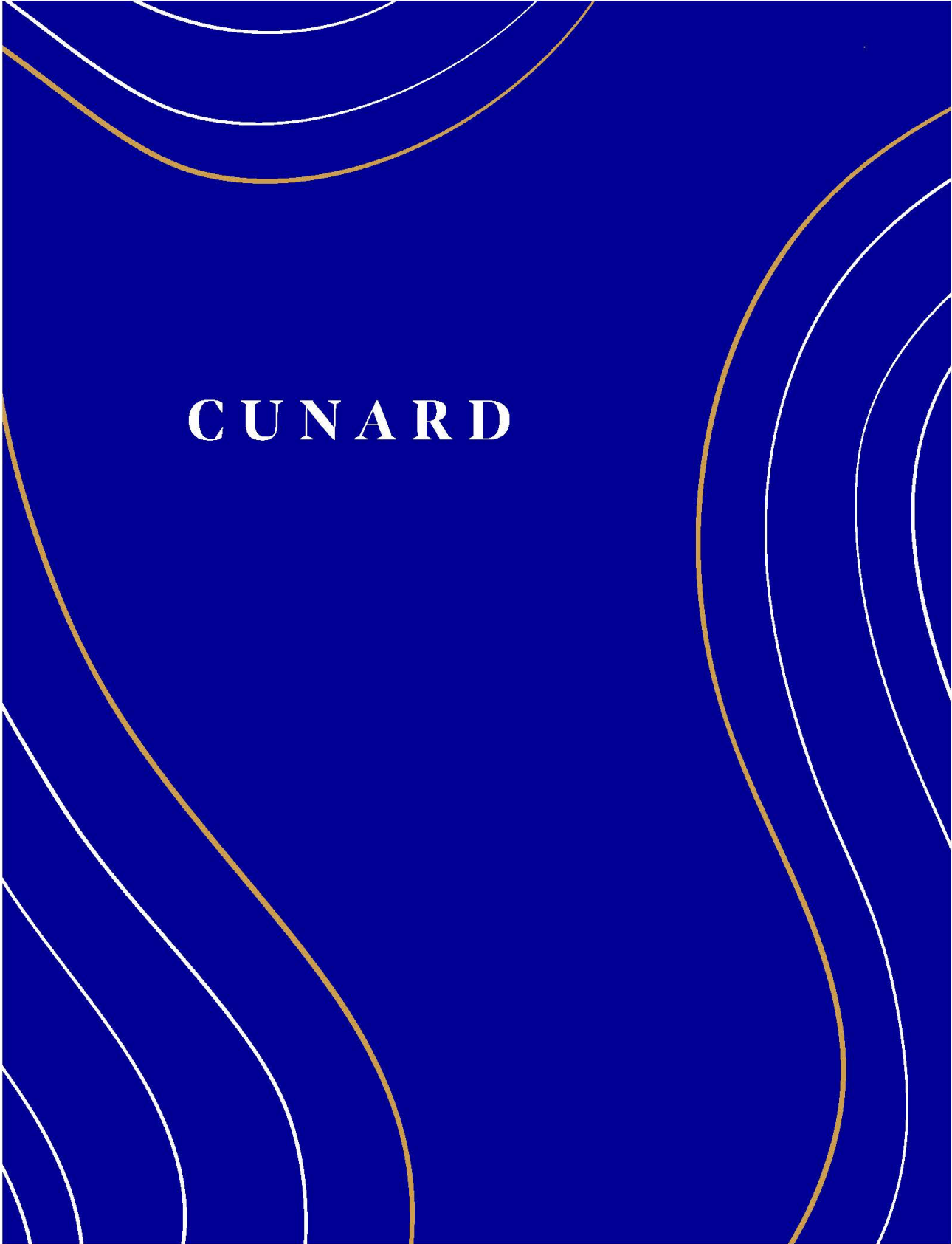

CUNARD

PROJECT OVERVIEW

Cunard Block is located on the prominent corner of 1325 Lower Water Street and Morris Street in downtown Halifax, and backs onto the harbour boardwalk. CUNARD is dynamic residential development, in partnership with Develop Nova Scotia, that will be constructed on this site.

The 16-storey development will target LEED® Gold certification and will feature 233 rental units, interior parking, ground level retail and new public spaces that will contribute to the revitalization of the area along Halifax's waterfront.

CUNARD residential units will include studio, one bedroom, one plus dens and two-bedroom. The building will feature large Signature and 16th floor Premium suites, plus Work | Live units that combine a street level retail space and an upper residence.

Resident amenities include 24-hour concierge service, a business lounge, expansive outdoor spaces with two amenity terraces which include a roof-top pool and hot tub, fire tables, barbecue and seating areas, and a dog run. Additionally, a large fitness centre and a resident great room with a chef's kitchen, dining room, lounge and games area. Parking levels include electric car charging stations, a bike room, car wash and a pet spa.

The public plaza will be activated by a mix of commercial retail units, restaurants, a secondary residential lobby as well as a mix of patios and terraces. Morris Street extension will feature commercial retail units, secondary office entrances, and pedestrian street extension to the boardwalk. A total of 18,835 square feet of retail / commercial will be included in the development.

The Cunard Block project has been designed to meet the needs of the challenging waterfront site and specifically to meet the goals of Develop Nova Scotia, and the design objectives of the Downtown Halifax LUB and Design Manual.

CUNARD

THE COMMUNITY

Southwest Properties values the importance of being a good community neighbour. In an effort to enhance our communications with the CUNARD project, we will be sending out periodic Community Updates. In conjunction with Develop Nova Scotia, these updates will help surrounding residents and businesses stay informed of on-site activities,

Construction and project updates and questions can be found or directed to **southwest.ca/cunard | email urbanhalifax@southwest.ca**

Information and questions on public spaces can be found or directed to **developns.ca | email info@developns.ca**

PEDESTRIANS

There will be minimal negative impact to pedestrian traffic on Lower Water Street and the waterfront board walk will remain accessible.

A trestle bypass path will be constructed across Halifax Port Authority lands adjacent to the construction area along the Halifax waterfront. The temporary path will allow pedestrians to access the boardwalk while CUNARD is under construction.

Temporary sidewalks will be put in place on Lower Water Street. Pedestrians will be protected from construction and vehicular traffic using concrete barriers and fencing. Accessibility requirements will be in place and the bike path will remain.

Working with Halifax Regional Municipality, a Construction Management Plan [CMP] is being prepared to mitigate any potential inconveniences during construction.

CUNARD

CONSTRUCTION TIMELINES

The construction of this project will include three phases – Site Preparation, Subgrade, Structure and Interior finishes.

SITE PREPARATION (March 2021 – June 2021)

Southwest is targeting March 2021 for the construction and installation of a pedestrian bridge on the southern end of the boardwalk to ensure continued public access and connectivity along the Halifax waterfront.

Building construction will commence in March with the excavation of the site and piling work taking place.

Cunard will feature above ground parking, thus deep foundation excavation work will not be required. Cunard's pile foundation design will result in a slab on grade parking level. This will take approximately 3 to 4 months to complete and formwork will begin during this period.

We will also be working with our partner [Develop Nova Scotia] to share information and re-engage the community on public spaces.

CUNARD

CONTACTS

Construction and project questions can be directed to:

Southwest Properties Limited

Suite 100, 1475 Lower Water Street

24 Hour Line 902.422.6412

Project updates are posted to Southwest's website. Sign-up to receive community updates and project updates can be found at:

<https://southwest.ca/developments/cunard/>

Or by emailing urbanhalifax@southwest.ca

CUNARD

CUNARD DEVELOPMENT

Thursday, January 14, 2021

SAMPLE UPDATE

Dear Residential, Retail, and Office Neighbours,

Southwest Properties is the developer for the mixed-use residential project to be constructed at 1325 Lower Water Street on the Cunard lot. Construction of the CUNARD development will take place over the next 34 months, with expected completion in late 2023.

Effective **Monday, January 18th** the public parking lot will be closed to prepare the construction site. Our partners at Develop Nova Scotia have notified monthly parkers of spaces available at the Salter and Foundation Place lots along Lower Water Street, which also provide short-term parking options.

Activity will be visible starting Friday, January 15th as the construction team begin locating equipment and installing fencing around the site perimeter. There will be minimal traffic and noise disruption to surrounding residents and businesses during this site activity.

Early March will see the construction and installation of a pedestrian bridge on the southern end of the boardwalk to ensure continued public access and connectivity along the Halifax waterfront.

Building construction will commence mid-March with the excavation of the site and piling work taking place. Cunard will feature above ground parking, thus deep foundation excavation work will not be required. Cunard's pile foundation requires above ground installation of posts to support the foundation of the structure. This will take approximately 3 to 4 months to complete before formwork on the building will start.

CUNARD

...2

All sub-contractors will be made aware of HRM guidelines and site activity will adhere to HRM's approved working hours and noise by-laws.

The dynamic development, in partnership with Develop Nova Scotia, will take shape on the 1.5 acre site at the intersection of Lower Water Street and Morris Street. When complete, CUNARD will feature 238 rental suites and lower level commercial and retail spaces. Develop Nova Scotia will build and manage the approximately 2 acres of improved and new public space and will be re-engaging the community to invite ideas and provide updates. CUNARD will be a high quality project which will contribute to the revitalization of the area and create new public spaces, creating a destination on the Halifax waterfront.

We appreciate your patience and co-operation and we look forward to introducing an exciting new residential and retail address to Halifax and with our partners at Develop Nova Scotia, vibrant new public spaces.

Southwest Properties values the importance of being a good community neighbour. In an effort to enhance our communications regarding the **CUNARD** project, we will be sending out periodic **Community Updates**. In conjunction with Develop Nova Scotia, these updates will help keep you apprised of what's happening, milestones and to address questions you may have.

If you would like to receive an electronic version of our community updates, please send your contact information to urbanhalifax@southwest.ca or visit our website for this project at southwest.ca

To learn more about the public spaces, visit developns.ca or email info@developns.ca

Appendix N – Rodent Control Plan

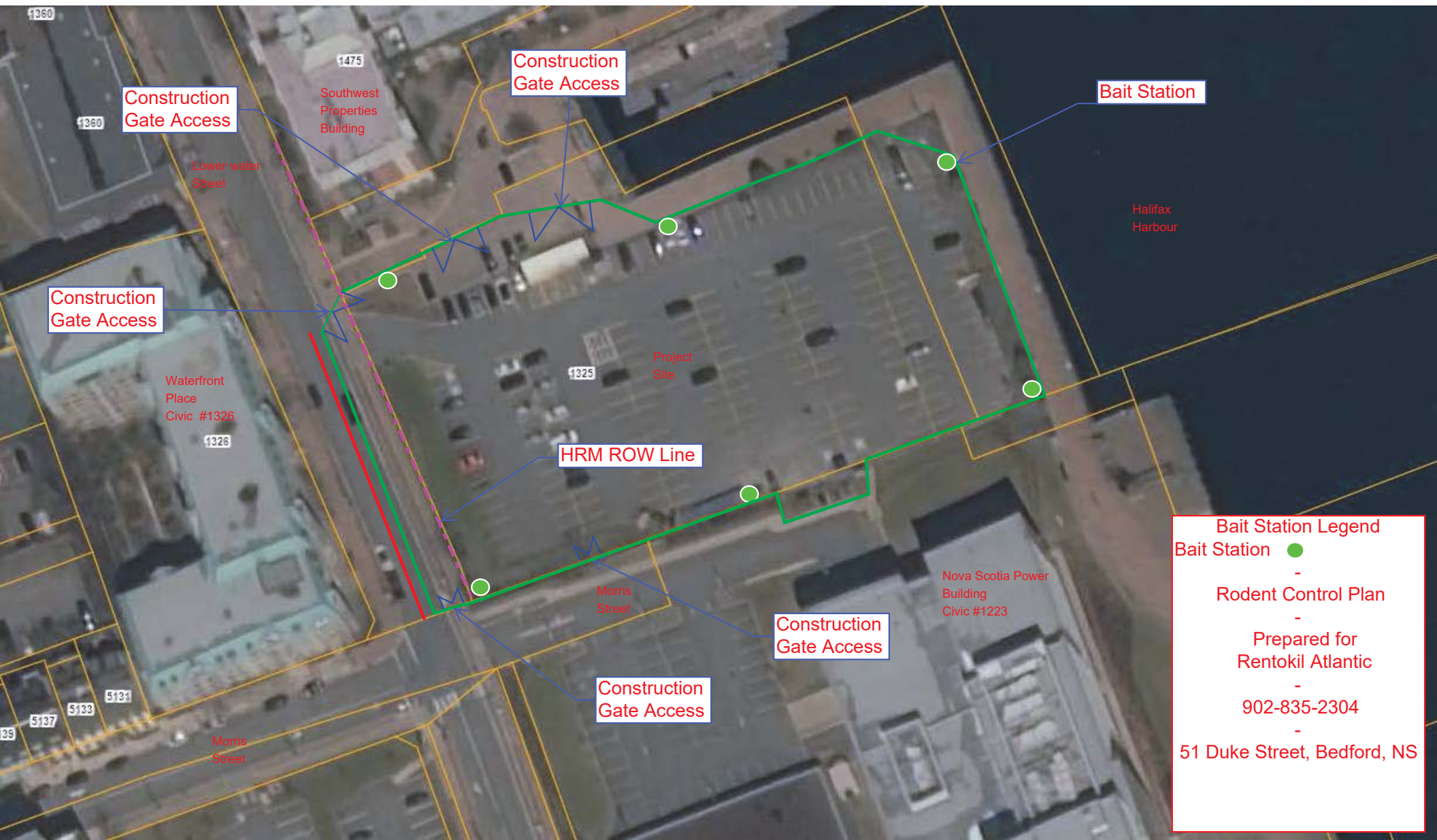

Bait Station Legend

Bait Station ●

-

Rodent Control Plan

-

Prepared for

Rentokil Atlantic

-

902-835-2304

-

51 Duke Street, Bedford, NS

Protecta®
EVO® **AMBUSH™**
 PATENT PENDING



THE MOST ADVANCED LOW-PROFILE BAIT STATION

PRODUCT FEATURES:

- ▶ Single locking mechanism for quick servicing
- ▶ Removable tray for easy cleaning
- ▶ Locking bait rods won't fall out during cleaning
- ▶ Dog & child tamper-resistant
- ▶ Can hold:
 - 4 - 1 oz. bait BLOX on 4 vertical rods
 - or -
 - T-Rex™ rat trap or Mini-Rex™ mouse trap
- ▶ Compatible with Sidekick® Load-N-Lock™ system



| PRODUCT | CODE | DIMENSIONS (in) | CASE QTY |
|---------------------|--------|------------------------|------------|
| Protecta Evo Ambush | EA2000 | 8 1/2 x 10 1/4 x 4 1/4 | 6 Stations |



More Than Meets The Eye

Madison, Wisconsin 53704 USA | Ph: (608) 241-0202 | Fax: (608) 241-9631

www.belllabs.com

ALL-WEATHER
BLOX™



CONTRAC®
ALL-WEATHER BLOX™

KILLS RATS, MICE & MEADOW VOLES*

Kills Warfarin Resistant Norway Rats

KEEP OUT OF REACH OF CHILDREN

CAUTION

See back panels for First Aid and additional precautionary statements.

ACTIVE INGREDIENT:

Bromadiolone (CAS #28772-56-7): 0.005%

OTHER INGREDIENTS†: 99.995%

†Contains Denatonium Benzoate TOTAL 100.000%

*Not permitted for use against the following species in California: Cotton rat, Eastern harvest mouse, Golden mouse, Polynesian rat, Meadow vole, White-throated woodrat, Southern plains woodrat, and Mexican woodrat.

NET WT:
18 lbs (8.2 kg)

FIRST AID
HAVE LABEL WITH YOU WHEN OBTAINING TREATMENT ADVICE

IF SWALLOWED:

- Call a poison control center, doctor, or 1-877-854-2494, or 1-800-858-7378** immediately for treatment advice.
- Have person sip a glass of water if able to swallow.
- Do not induce vomiting unless told to do so by the poison control center or doctor.

IF ON SKIN OR CLOTHING:

- Take off contaminated clothing. Rinse skin immediately with plenty of water for 15–20 minutes.
- Call a poison control center or doctor for treatment advice.

IF IN EYES:

- Hold eye open and rinse slowly and gently with water for 15–20 minutes.
- Remove contact lenses, if present, after the first 5 minutes, then continue rinsing eye.
- Call a poison control center, doctor, or 1-877-854-2494 immediately for treatment advice.

** Also call this number for information on health concerns and pesticide incidents.

NOTE TO PHYSICIAN

If swallowed or absorbed through the skin, this material may reduce the clotting ability of the blood and cause bleeding. If ingested, administer Vitamin K₁ intramuscularly or orally. Repeat as necessary based on monitoring of prothrombin times.

TREATMENT FOR PET POISONING
 If animal eats bait, call veterinarian at once.

NOTE TO VETERINARIAN

Anticoagulant Bromadiolone: For animals ingesting bait and/or showing poisoning signs (bleeding or elevated prothrombin times), give Vitamin K₁. If needed, check prothrombin times every 3 days until values return to normal (up to 30 days). In severe cases, blood transfusions may be needed.

DIRECTIONS FOR USE

It is a violation of Federal law to use this product in a manner inconsistent with its labeling.
READ THIS LABEL: Read this entire label and follow all use directions and use precautions. Use only for sites, pests, and application methods described on this label.

IMPORTANT: Do not expose children, pets, or nontarget animals to rodenticides. To help to prevent exposure:

1. Store unused product out of reach of children and pets.
2. Apply bait in locations out of reach of children, pets, domestic animals and nontarget wildlife, or in tamper-resistant bait stations. These stations must be resistant to destruction by dogs and by children under six years of age, and must be used in a manner that prevents such children from reaching into bait compartments and obtaining bait. If bait can be shaken from bait stations when they are lifted, units must be secured or otherwise immobilized. Stronger bait stations are needed in areas open to hoofed livestock, raccoons, bears, or other potentially destructive animals, or in areas prone to vandalism.
3. Dispose of product container and unused, spoiled, or unconsumed bait as specified on this label.

Bait stations are mandatory for outdoor, above-ground use. Tamper-resistant bait stations must be used wherever children, pets, non-target mammals, or birds may have access to the bait placement location.

USE RESTRICTIONS: This product may only be used to control the following rodent pests in and around man-made structures: House mouse (*Mus musculus*), Norway rat (*Rattus norvegicus*), Roof rat (*Rattus rattus*), Cotton mouse (*Peromyscus gossypinus*), Cotton rat* (*Sigmodon hispidus*), Deer mouse (*Peromyscus maniculatus*), Eastern harvest mouse* (*Reithrodontomys humuli*), Golden mouse* (*Ochrotomys nuttalli*), Polynesian rat* (*Rattus exulans*), Meadow vole* (*Microtus pennsylvanicus*), White-footed mouse (*Peromyscus leucopus*), White-throated woodrat* (*Neotoma albigula*), Southern plains woodrat* (*Neotoma micropus*), and Mexican woodrat* (*Neotoma mexicana*). This product must be used in and within 100 feet of man-made structures constructed in a manner so as to be vulnerable to commensal rodent invasions and/or to harboring or attracting rodent infestations. Examples of such structures include homes and other permanent or temporary residences, food processing facilities, industrial and commercial buildings, trash receptacles, agricultural and public buildings, transport vehicles (ships, trains, aircraft), docks and port or terminal buildings and related structures around and associated with these sites. Fence and perimeter baiting, beyond 100 feet from a structure as defined above, is prohibited. This product must not be applied directly to food or feed crops.

587CB-9



Kills Warfarin Resistant Norway Rats

Norway rats, roof rats, and house mice may consume a lethal dose in one night's feeding with first dead rodents appearing four or five days after feeding begins.

ACTIVE INGREDIENT:
 Bromadiolone (CAS #28772-56-7): 0.005%
 OTHER INGREDIENTS: 99.995%
 †Contains Denatonium Benzoate TOTAL 100.000%

**KEEP OUT OF REACH OF CHILDREN
 CAUTION**

See side panels for First Aid and additional precautionary statements.

STORAGE AND DISPOSAL

Do not contaminate water, food or feed by storage or disposal.
Pesticide Storage: Store only in original container in a cool, dry place inaccessible to children and pets. Keep containers closed and away from other chemicals.
Pesticide Disposal: Wastes resulting from the use of this product may be placed in trash or delivered to an approved waste disposal facility.
Container Handling: Nonrefillable container. Do not reuse or refill this container. [Plastic:] Offer for recycling or reconditioning; or puncture and dispose of in a sanitary landfill; or by incineration. In most states, burning is not allowed.

WARRANTY: To the extent consistent with applicable law, seller makes no warranty, expressed or implied, concerning the use of this product other than indicated on the label. Buyer assumes all risk of use and/or handling of this material when such use and/or handling is contrary to label instructions.

NET WEIGHT: 18 lbs (8.2 kg)

EPA REG. NO. 12455-79

EPA EST. NO. 12455-WI-1



DIRECTIONS FOR USE (Continued from other panel)

Burrow baiting with Contrac All-Weather Blox is prohibited.

Do not place near or inside ventilation duct openings. Do not contaminate water, food, feedstuffs, food or feed handling equipment, or milk or meat handling equipment or surfaces that come into direct contact with food. When used in USDA inspected facilities, this product must be applied in tamper-resistant bait stations. Do not broadcast bait. Do not use this product in sewers.

Do not sell this product in individual containers holding less than 16 pounds of bait.

SELECTION OF TREATMENT AREAS: Determine areas where rats, mice, or meadow voles* will most likely find and consume the bait. Generally, these areas are along walls, by gnawed openings, in corners and concealed places, between floors and walls, or in locations where rats, mice, or meadow voles*, or their signs have been seen. Protect bait from rain and snow. Remove as much alternative food as possible.

APPLICATION DIRECTIONS:
RATS: Place 3 to 16 bait blocks (at intervals of 15 to 30 feet) per placement in infested areas. Maintain an uninterrupted supply of fresh bait for at least 10 days or until signs of rat activity cease.
MICE AND MEADOW VOLES*: Place 1 block per placement. Space placements at 8- to 12-foot intervals in infested areas. Two blocks may be needed at points of very high activity. Maintain an uninterrupted supply of fresh bait for at least 15 days or until signs of mouse or meadow vole* activity cease.
FOLLOW-UP: Replace contaminated or spoiled bait immediately. Wearing gloves, collect and dispose of all dead, exposed animals and leftover bait. To prevent reinfestation, limit sources of rodent food, water, and harborage as much as possible. If reinfestation does occur, repeat treatment. Where a continuous source of infestation is present, establish permanent bait stations and replenish as needed.

**PRECAUTIONARY STATEMENTS
 HAZARDS TO HUMANS AND DOMESTIC ANIMALS**

CAUTION: Harmful if swallowed or absorbed through the skin. Keep away from children, domestic animals and pets. Do not get in eyes, on skin or on clothing.
 All handlers (including applicators) must wear: shoes plus socks, and waterproof gloves. Any person who retrieves carcasses or unused bait following application of this product must wear gloves.

User Safety Requirements

Follow manufacturer's instruction for cleaning/maintaining PPE. If no such instructions for washables, use detergent and hot water. Keep and wash PPE separately from other laundry. Remove PPE immediately after handling this product. Wash the outside of gloves before removing. As soon as possible, wash hands thoroughly after applying bait and before eating, drinking, chewing gum, using tobacco or using the toilet and change into clean clothing.

ENVIRONMENTAL HAZARDS

This product is extremely toxic to fish, birds and other wildlife. Dogs and predatory and scavenging mammals and birds might be poisoned if they feed upon animals that have eaten this bait. Do not apply this product directly to water or to areas where surface water is present or to intertidal areas below the mean high water mark. Runoff also may be hazardous to aquatic organisms in water adjacent to treated areas. Do not contaminate water when disposing of equipment wash water or rinsate.

*Not permitted for use against the following species in California: Cotton rat, Eastern harvest mouse, Golden mouse, Polynesian rat, Meadow vole, White-throated woodrat, Southern plains woodrat, and Mexican woodrat.

Product Code: CB4051

090415/09-15

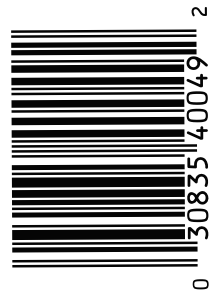



DETEX[®] BLOX with LUMITRACK

SAFETY DATA SHEET

ACCORDING TO REGULATION: OSHA
Hazard Communication Standard 29 CFR 1910.1200

DATE OF ISSUE:
January 2016

PREPARED BY:
CAR

SECTION 1. PRODUCT AND COMPANY IDENTIFICATION

Product Identifier: DETEX[®] BLOX with LUMITRACK
EPA Registration Number: NA
Relevant identified uses of the substance or mixture and uses advised against
Relevant identified uses: Activity Monitoring - Ready to use
Uses advised against: Use only for the purpose described above

MANUFACTURER/SUPPLIER:

Bell Laboratories, Inc.
3699 Kinsman Blvd.
Madison, WI 53704, USA
Email: sds@belllabs.com
Phone: 608-241-0202
Medical or Vet Emergency: 877-854-2494 or 952-852-4636
Spill or Transportation Emergency: 800-424-9300 (CHEMTREC)

SECTION 2. HAZARDS IDENTIFICATION

Classification according to Regulation OSHA 1910.1200(d): Not classified
Signal Word: None
See Section 15 for information on FIFRA applicable safety, health, and environmental classifications.

SECTION 3. COMPOSITION/INFORMATION ON INGREDIENTS

| Component | CAS No. | % By weight |
|---|-------------|-------------|
| Inert and Non-Hazardous Ingredients (Unlisted components are non-hazardous) | Proprietary | 100.00% |

SECTION 4. FIRST AID MEASURES

Description of first aid measures
Ingestion: Non-Toxic
Inhalation: Not applicable.
Eye contact: Non-Toxic
Skin contact: Non-Toxic
Most important symptoms and effects, both acute and delayed
Non-Toxic
Advice to physician: Non-Toxic
Advice to Veterinarian: Non-Toxic

SECTION 5. FIRE-FIGHTING MEASURES

Extinguishing media
Suitable Extinguishing Media: water, foam or inert gas.
Unsuitable Extinguishing Media: None known.
Special hazards arising from the mixture: High temperature decomposition or burning in air can result in the formation of toxic gases, which may include carbon monoxide.
Advice for firefighters: Wear protective clothing and self-contained breathing apparatus.

SECTION 6. ACCIDENTAL RELEASE MEASURES

Personal precautions, protective equipment and emergency procedures: None. Non-Toxic
Environmental precautions: None. Non-Toxic
Methods and materials for containment and cleaning up
For Containment: None. Non-Toxic
For Cleaning Up: None. Non-Toxic
Reference to other sections: Refer to Sections 7, 8 & 13 for further details of personal precautions, personal protective equipment and disposal considerations.

SECTION 7. HANDLING AND STORAGE

Precautions for safe handling: Do not use near heat sources, open flame, or hot surfaces. Non-Toxic.

Conditions for safe storage, including any incompatibilities: None. Non-Toxic

SECTION 8. EXPOSURE CONTROLS/PERSONAL PROTECTION

Established Limits

| Component | OSHA | ACGIH | Other Limits |
|-----------|-----------------|-----------------|-----------------|
| None | Not Established | Not Established | Not Established |

Appropriate Engineering Controls: None. Non-Toxic

Occupational exposure limits: None. Non-Toxic

Personal Protective Equipment:

Respiratory protection: Not required

Eye protection: Not required

Skin protection: None. Non-Toxic

Hygiene recommendations: None. Non-Toxic

SECTION 9. PHYSICAL AND CHEMICAL PROPERTIES

Information on basic physical and chemical properties

| | |
|--|---|
| Appearance/Color: | Tan wax block |
| Odor: | Sweet grain-like |
| Odor Threshold: | Not applicable, odor not associated with a hazardous material. |
| pH: | Not applicable, is not dispersible with water. |
| Melting point: | Not applicable |
| Boiling point: | Not applicable |
| Flash point: | Not applicable, does not contain components classified as flammable. |
| Evaporation rate: | Not applicable, is a solid. |
| Flammability: | Not applicable, is a solid. |
| Upper/lower flammability or explosive limits: | Not applicable, does not contain components classified as flammable or explosive. |
| Vapor Pressure: | Not applicable |
| Vapor Density: | Not applicable, is a solid |
| Relative Density: | 1.13 g/mL @ 20°C |
| Solubility (water): | Not water soluble |
| Solubility (solvents): | Not applicable |
| Partition coefficient: n-octanol/water: | Not applicable |
| Auto-ignition temperature: | Not applicable, does not contain components classified as flammable. |
| Decomposition temperature: | Not applicable |
| Viscosity: | Not applicable, is not a liquid. |

SECTION 10. STABILITY AND REACTIVITY

Reactivity: Not Applicable

Chemical stability: Not Applicable

Possibility of hazardous reactions: Refer to Hazardous decomposition products

Conditions to avoid: Avoid extreme temperatures (below 0°C or above 40°C).

Incompatible materials: Not Applicable

Hazardous decomposition products: Not Applicable

SECTION 11. TOXICOLOGICAL INFORMATION

Information on toxicological effects

Acute Toxicity

LD50, oral (ingestion): Not Toxic

LD50, dermal (skin contact): Not Toxic

LC50, inhalation: Not Toxic

Skin corrosion/irritation: Not Toxic

Serious eye damage/Irritation: Not Toxic.

Respiratory or skin sensitization: Not Toxic

Germ cell mutagenicity: Not Toxic

Carcinogenicity: Not Toxic

| | | | |
|-------------------|------------|-------------|-------------|
| Components | NTP | IARC | OSHA |
| None | NA | NA | NA |

Reproductive Toxicity: Not Toxic
Aspiration Hazard: Not Toxic
Target Organ Effects: Not Toxic

SECTION 12. ECOLOGICAL INFORMATION

Ecotoxicity Effects: Not Toxic
Persistence and degradability: Not Toxic
Bioaccumulative potential: Not Toxic
Mobility in Soil: Not Toxic.
Other adverse effects: None.

SECTION 13. DISPOSAL CONSIDERATIONS

Disposal: Wastes resulting from the use of this product may be placed in trash, on-site, or at an approved waste disposal facility. Dispose of all wastes in accordance with all Federal, state and local regulations.

SECTION 14. TRANSPORT INFORMATION

UN number: Not regulated
UN proper shipping name: Not regulated
Transport hazard class(es): Not regulated
Packing group : Not regulated
Environmental Hazards
DOT Road/Rail: Not considered hazardous for transportation via road/rail.
DOT Maritime: Not considered hazardous for transportation by vessel.
DOT Air: Not considered hazardous for transportation by air.
Freight Classification: LTL Class 60
Transport in bulk according to Annex II of MARPOL 73/78 and the IBC code: Not applicable
Special precautions for user: None

SECTION 15. REGULATORY INFORMATION

Safety, health and environmental regulations/legislation specific for the substance or mixture: Not applicable
Signal Word: None
Precautionary Statements: None
Potential Health Effects:
Eye Contact: May cause irritation
Skin Contact: Non-irritating to the skin
Ingestion: Not harmful if swallowed

TSCA: All components are listed on the TSCA Inventory or are not subject to TSCA requirements
CERCLA/SARA 313: Not Toxic
CERCLA/SARA 302: Not Toxic

SECTION 16. OTHER INFORMATION

For additional information, please contact the manufacturer noted in Section 1.

| | | | | |
|-------------|-----------------------|--------------------------|-------------------------|----------------------------|
| NFPA | Health: 0 (Not Toxic) | Flammability: 1 (slight) | Reactivity: 0 (stable) | Specific Hazard: None |
| HMIS | Health: 0 (Not Toxic) | Flammability: 1 (slight) | Reactivity: 0 (minimal) | Protective Equipment: None |

Disclaimer: The information provided in this Safety Data Sheet has been obtained from sources believed to be reliable. Bell Laboratories, Inc. provides no warranties; either expressed or implied, and assumes no responsibility for the accuracy or completeness of the data contained herein. This information is offered for your consideration and investigation. The user is responsible to ensure that they have all current data, including the approved product label, relevant to their particular use.

Rentokil

Ehrlich | Western | Presto-X
Your Local Pest Control Experts

PestNetOnline

The complete online
pest management
and reporting solution

Randy Hobbs
Account Executive

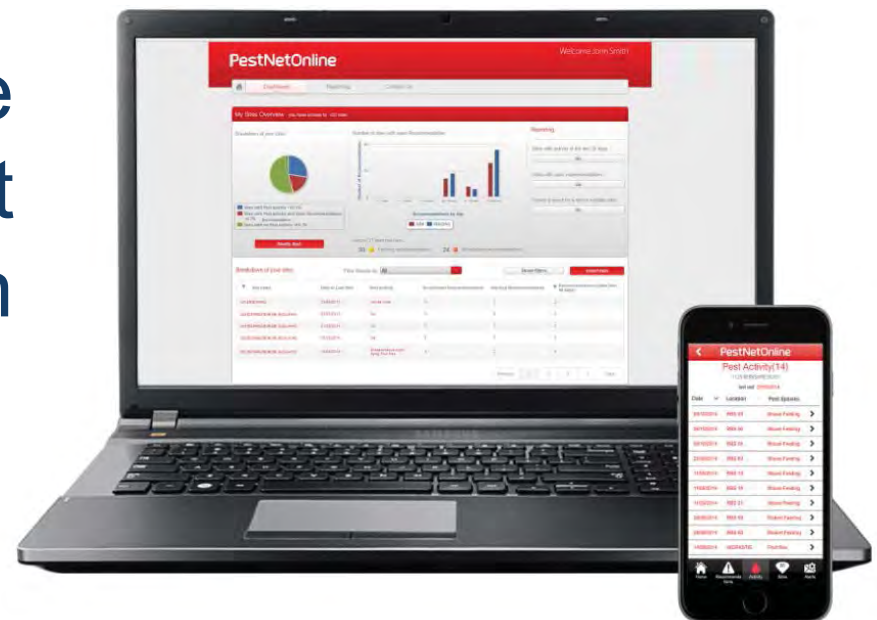

What is PestNetOnline?

Online reporting and analysis of all pest activity

- Intuitive and easy to use
- Complete visibility to minimize risks
- Increased efficiency with information at your fingertips
- Minimize exposure with all your pest control records and data in one place
- Stay in control with a smartphone app



Who is PestNetOnline for?

For Food and Beverage, Pharmaceutical, Logistics, Healthcare, Commercial/Residential Property, and Retail... any business that needs online pest management and reporting

Offering:

- Personalized Dashboard
- Multiple and Single Site Locations
- Trend Analysis
- Detailed Service Reports
- Recommendation System
- Interactive Site Maps
- Documentation Availability
- Material Usage Reports
- Proof of Service



How PestNetOnline works...

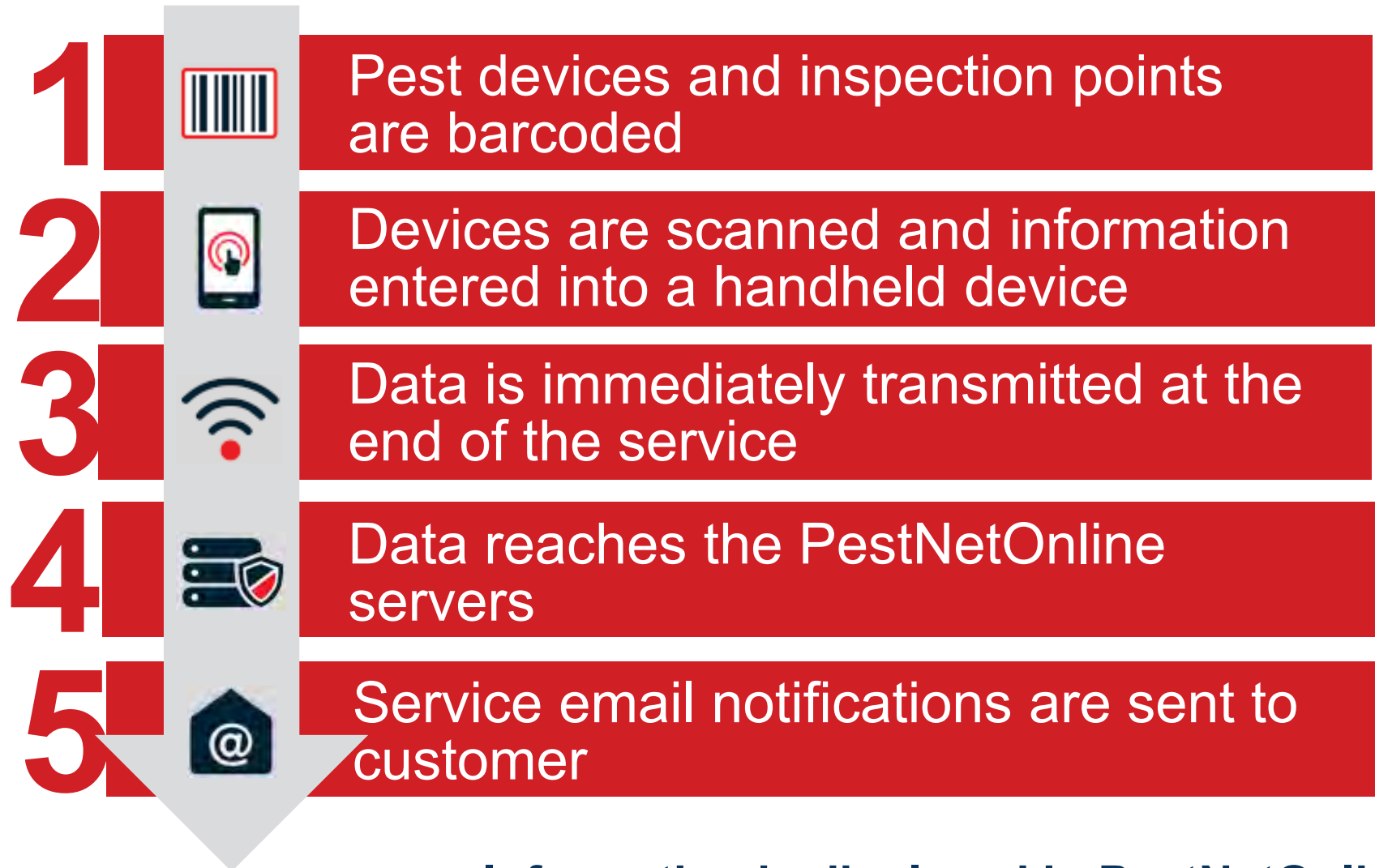

PestNetOnline

Information is displayed in PestNetOnline and mobile applications

PestNetOnline

Single site locations

- Provides a comprehensive review of all visit details
- Pest Activity and Recommendation charts summarizing at a high level all issues
- Visit Filters allowing you to quickly locate series of visit and types of visits
- Review and reprint any Proof of Service
- Navigation tabs take you directly to Tasks, Recommendations, Pest Activity and Material Usage detail screen – quickly and easily

The screenshot displays the PestNetOnline dashboard for a client. The top navigation bar includes 'Dashboard', 'Reporting', 'Service History', 'Audit Compliance', 'Documents', and 'Contact Us'. The main content area is divided into several sections:

- Site Overview:** Features a 'Recommendations chart by age' (a bar chart showing 12 pending recommendations) and a table of 'Recommendations outstanding' with columns for ID, Visit date, Type, Status, and Detail icon. The table lists five structural recommendations from 11/04/2014, all with a yellow status indicator.
- Rentokil Visits:** A pie chart showing 'Rentokil visits breakdown' over the last 12 months, with 71.4% routine visits and 28.6% callout visits.
- My Contract:** Displays contract details including Contract Number (05003654,20013654,20021706), Start Date (22/07/2013), and ISO 9001 status (No).

At the bottom, there is a 'Site summary' section for '5701 Park Ave' showing the last visit date as 11/04/2014 and a table of activity by zone:

| Building | Floor | Zone | Activity | Recommendations |
|----------|-------|----------|----------|-----------------|
| BUILDING | FLOOR | Exterior | Yes | 0 |
| BUILDING | FLOOR | Interior | Yes | 1 |

PestNetOnline

For multi site locations

- A dashboard that summarizes all activity
- My Sites allows you to see an overview of your locations
- Navigation shortcuts allowing you to quickly and effortlessly research visit activity
- Link to all related information
- Export data for custom analysis

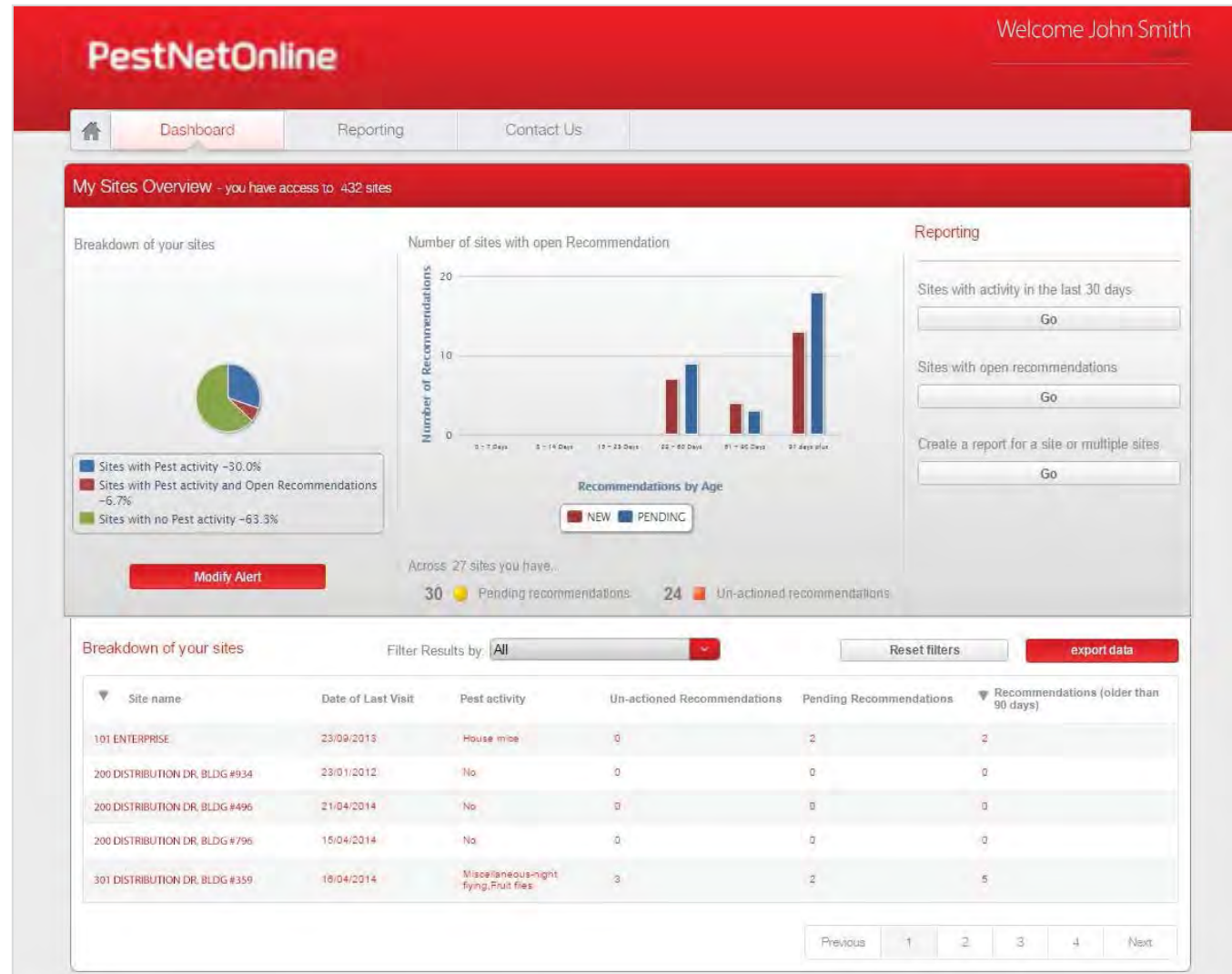

PestNetOnline

The screenshot shows the PestNetOnline web interface. At the top, there is a red header with the logo and a user greeting. Below the header is a navigation bar with 'Dashboard', 'Reporting', and 'Contact Us' links. The main content area is divided into two columns. The left column is titled 'Existing reports' and contains a 'Create a new report' form. The right column is titled 'Create new' and contains two buttons for report types. The 'Create a new report' form includes a title input field, a step indicator, radio buttons for report type and format, an email address field, frequency options, site location options, and a list of sites to report on.

PestNetOnline Welcome Client Name

Dashboard Reporting Contact Us

Existing reports

Create new

Create a new report

Please enter a report title...

Pest Activity

1) Select report type and location

Type of report

All Pest activity Recommendations Preparations

What format should the report be

Excel pdf

Where would you like this report emailed to?

john.pfeffer@rentokil.com

When would you like the report to run?

One Off Scheduled

What site locations would you link to report on?

All Internal External

Which sites would you like to report on? All

| | |
|--|-------------------------------------|
| PestNetOnline Demo Account (E) (High Dependency) | <input checked="" type="checkbox"/> |
| PestNetOnline Demo Account (A) (Commercial) | <input checked="" type="checkbox"/> |

continue

Pest activity, recommendations and preparations report

Visits and tasks report

Analysis and reports

- Provides quick, ad-hoc snapshot analysis reporting on all pest and device type activity
- Reports can be created to document Pest Activity, Recommendations, Visit Performance, Task Performance and Material Usage
- Reports are distributed to you via email
- Can be created and ran once, or proactively scheduled on a Daily, Week, Monthly or Quarterly based upon your needs
- Many options available to customize a snapshot view of Pest Activity

PestNetOnline

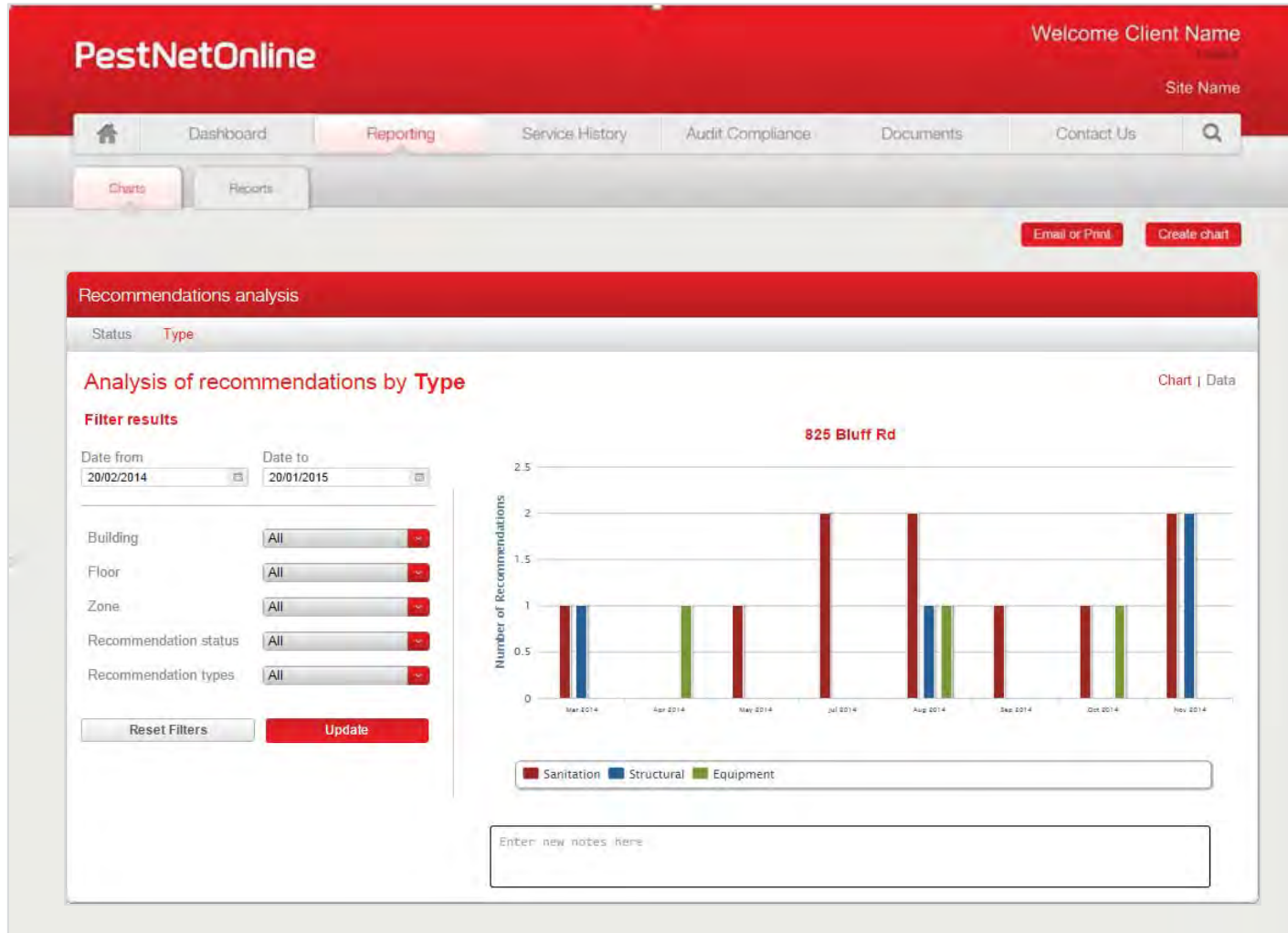

- Options to review an entire worksite, or specific Buildings / Floor / Zones within your worksite
- Feature rich with multiple date range options
- Provides quick, ad-hoc snapshot analysis on all pest activity
- Add commentary to charts

Rentokil

Ehrlich | Western | Presto-X
Your Local Pest Control Experts

PestNetOnline

For high dependency customers

- A dedicated Audit Checklist page
- For AIB, BRC, and other 3rd Party Auditors, a single page that brings together all necessary visit details and links to related information

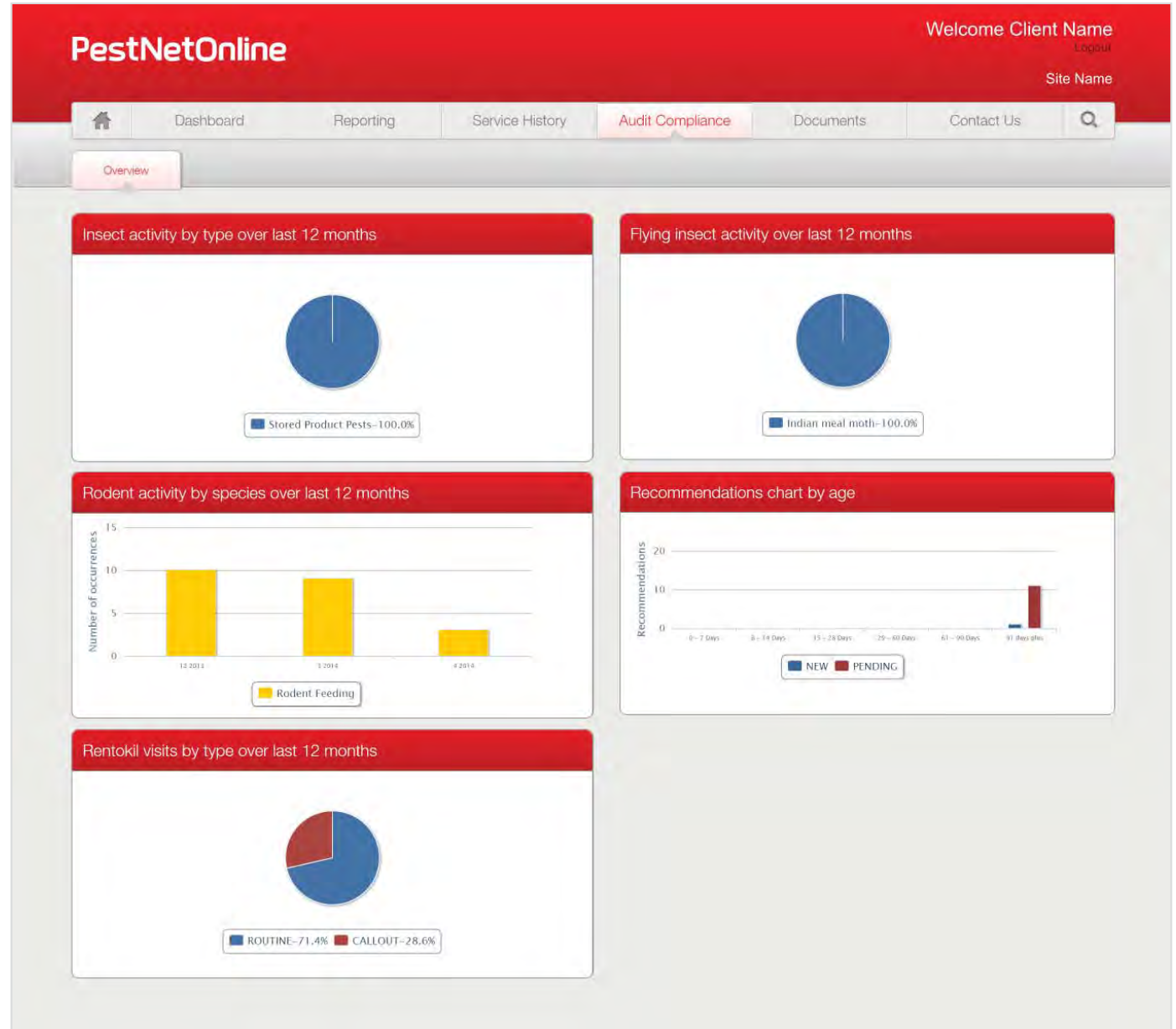

PestNetOnline

Site plans for high dependency and commercial customers

- Provide an interactive, graphic representation of device location
- Filters allow you to locate specific types (Mechanical Rodent Traps, Pheromone, etc.) quickly and easily
- Site Maps may also be printed if desired

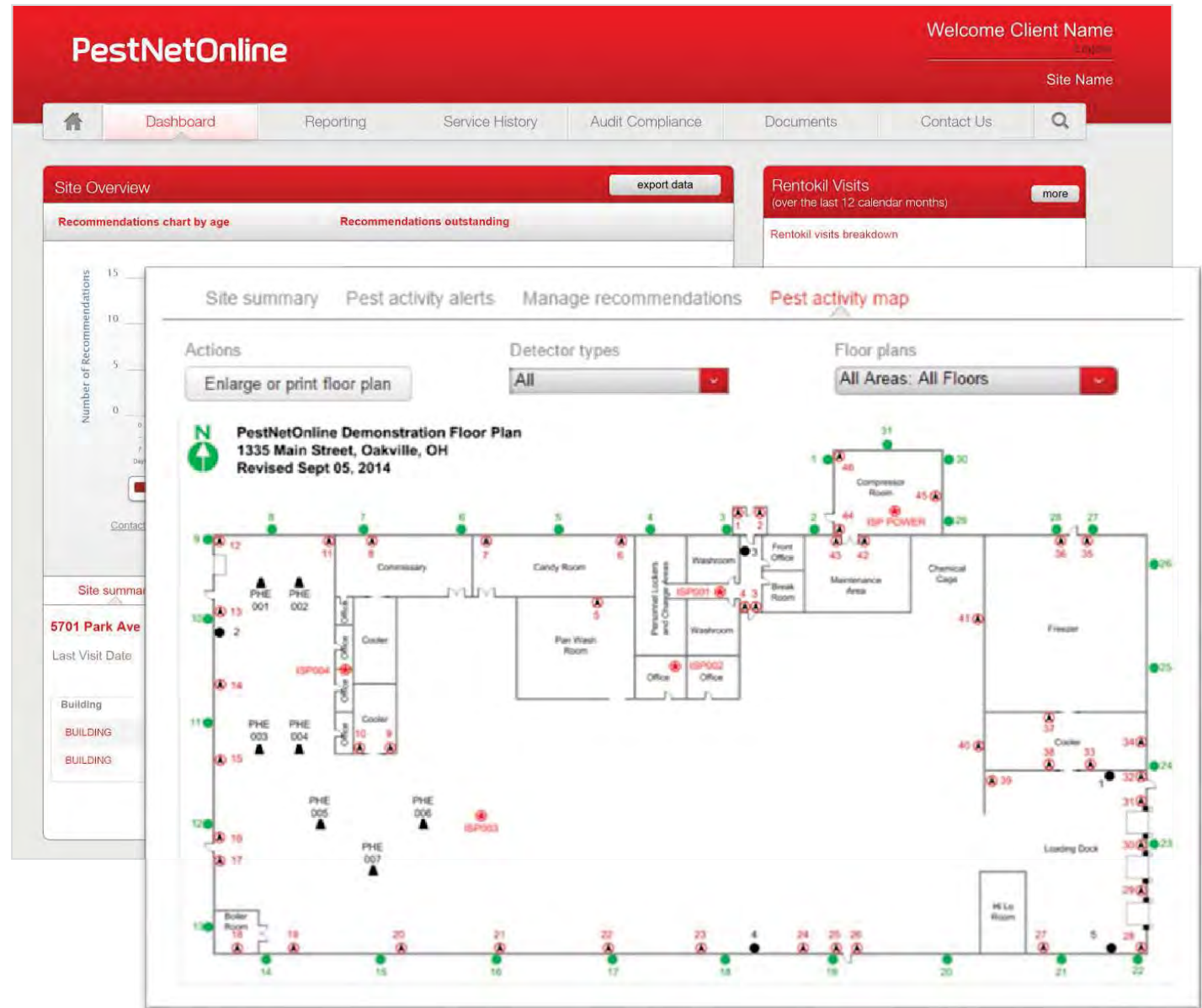

PestNetOnline

Site Documents, available to all users of PestNetOnline compliments all printed log book information electronically

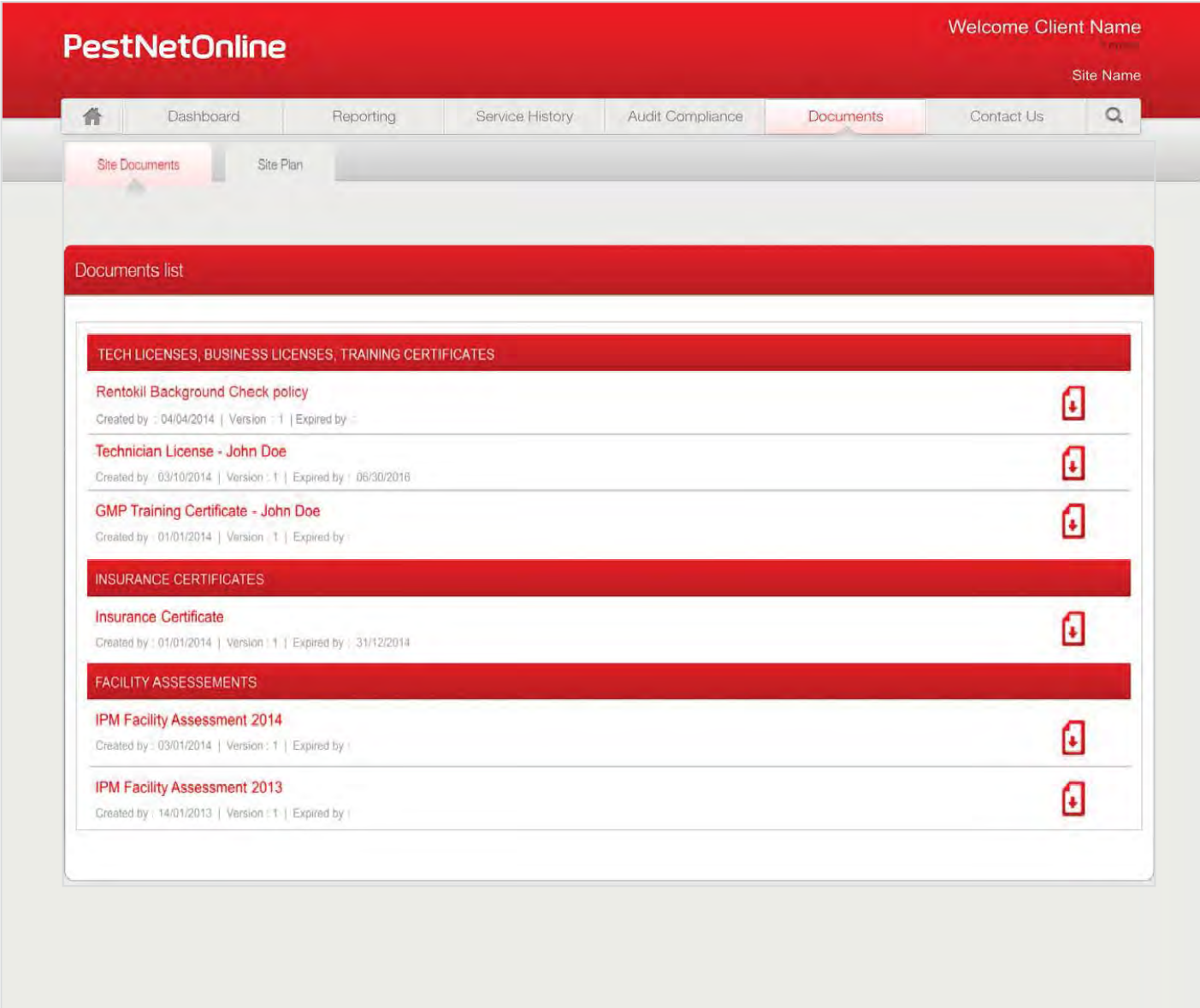

PestNetOnline Smartphone App

- **Home Screen**
 - Open recommendations
 - Instances of activity (last 90 days)
- **Recommendations**
 - Open recommendations total and by site
 - Open recommendations within a single site
 - Individual recommendation detail
 - Update the recommendation on the spot!
- **Activity**
 - Overall activity and activity instances by site
 - Last 90 days activity within a single site
 - Activity details and materials used
- **Site list and recommendation and activity indicators**
- **Email alerts creation**

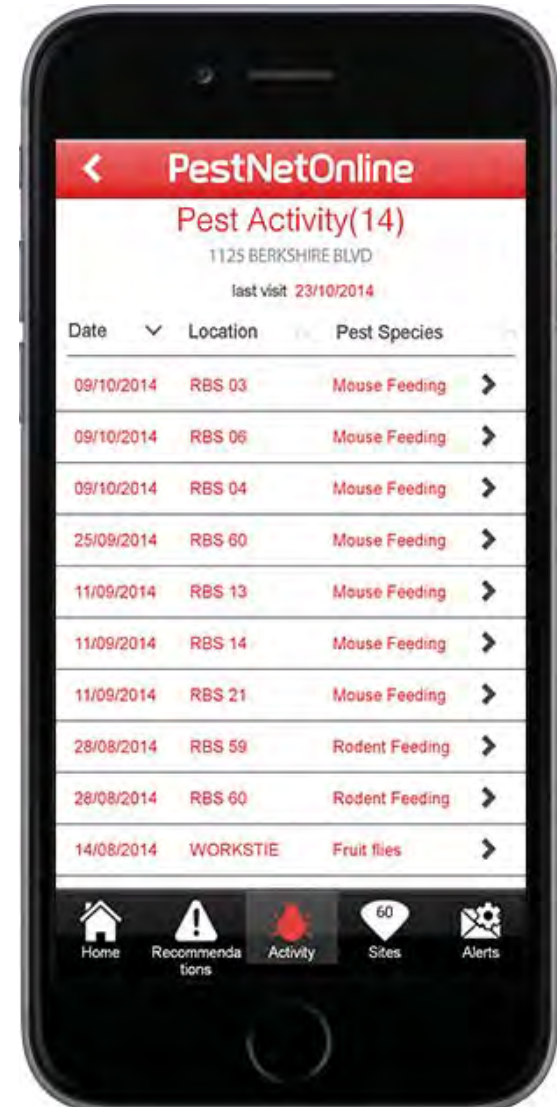

PestNetOnline Flexibility

PestNetOnline offers three levels of functionality

- Whether you are a homeowner, local retailer, business with multiple branches or manufacturer, PestNetOnline will meet all of your business needs

| Level | Residential | Commercial | High Dependency |
|-------------------------------|--|--|--|
| Functionality | Privately owned residences, condos, and townhouses | Commercial organizations that do not require third party audit support | Businesses and organizations who utilize any third party audit group |
| Barcode Structure | One barcode is required | ✓ | ✓ |
| Materials Usage | Only through reporting | ✓ | ✓ |
| Pest Activity | ✓ | ✓ | ✓ |
| Updating Recommendations | ✓ | ✓ | ✓ |
| Visit Details | ✓ | ✓ | ✓ |
| Single Site Reporting | ✓ | ✓ | ✓ |
| Documents | ✓ | ✓ | ✓ |
| Reports | ✓ | ✓ | ✓ |
| Smartphone app (lite version) | ✓ | ✓ | ✓ |
| Alerts | X | ✓ | ✓ |
| Multi-Site Reporting | X | ✓ | ✓ |
| Detector History | X | ✓ | ✓ |
| Trends Analysis | X | ✓ | ✓ |
| Tasks | X | ✓ | ✓ |
| Site Plans | X | X | ✓ |
| Audit Compliance | X | X | ✓ |

PestNetOnline

For more information visit pno1.rentokilna.com

Appendix O – CMP’s TCP & PMP Inspection Records

Appendix P – Concrete Delivery Schematic

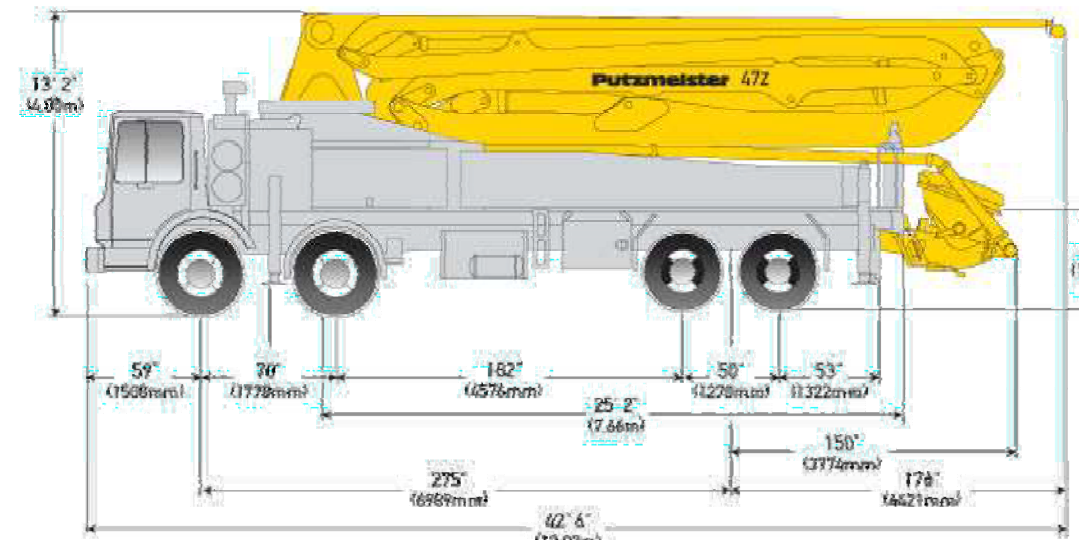

47Z

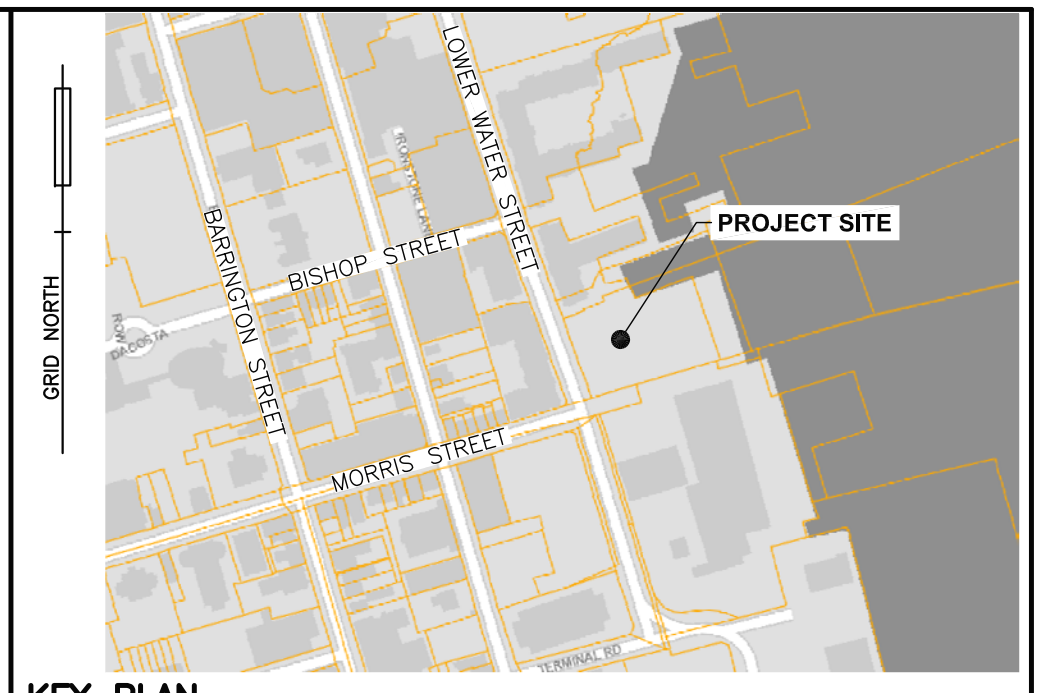
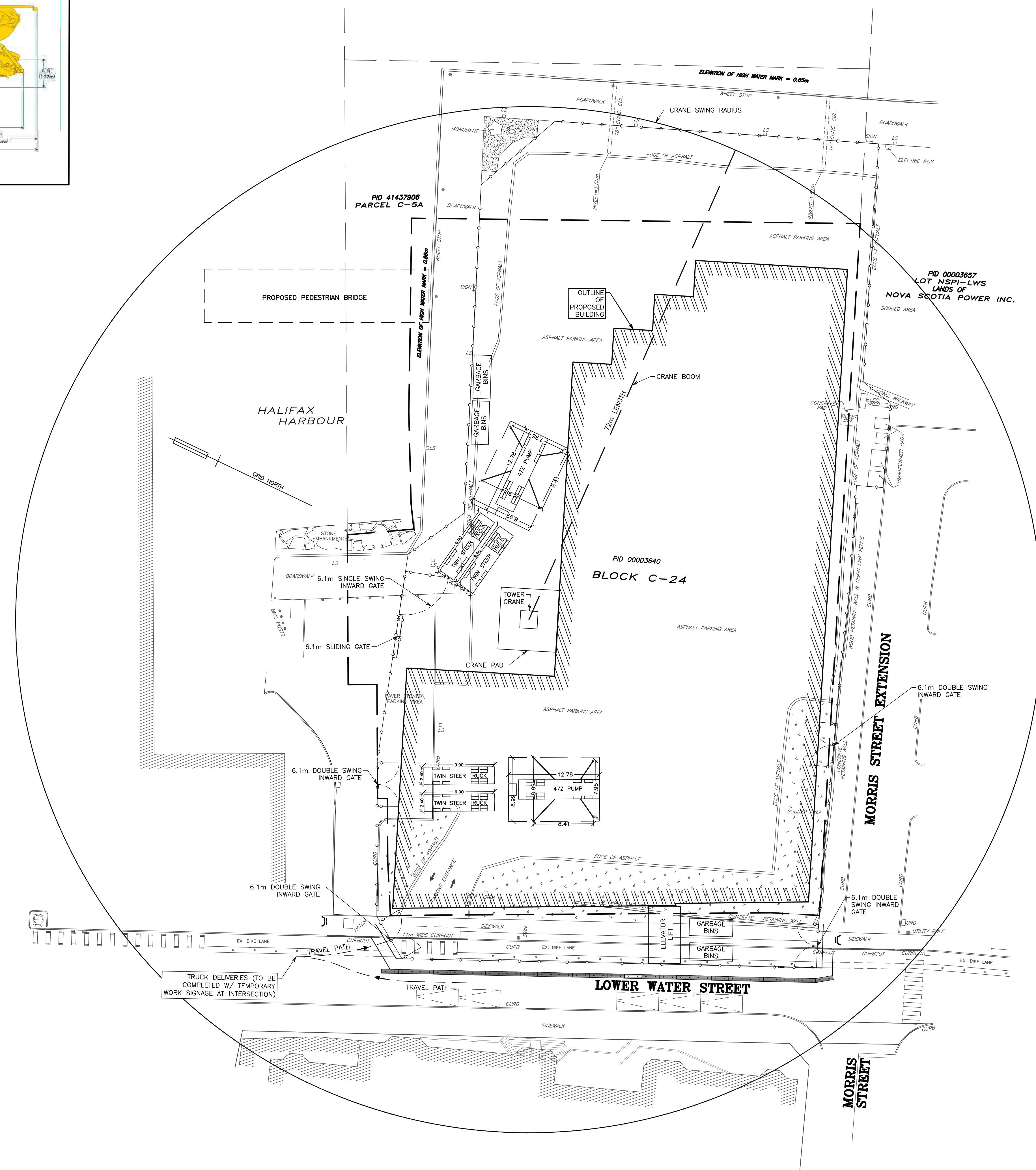

| EXISTING | | PROPOSED | |
|---|------------------------------------|---|------------------------------------|
| 25.0 | CONTOUR LINE | 25.0 | CONTOUR LINE |
| BF | CURB STOP/GATE/BUTTERFLY VALVE | BF | CURB STOP/GATE/BUTTERFLY VALVE |
| Fire Hydrant Symbol | FIRE HYDRANT | Fire Hydrant Symbol | FIRE HYDRANT |
| Concrete Thrust Block Symbol | CONCRETE THRUST BLOCK | Concrete Thrust Block Symbol | CONCRETE THRUST BLOCK |
| Siamese Connection Symbol | SIAMESE CONNECTION | Siamese Connection Symbol | SIAMESE CONNECTION |
| Catch Basin/Pit Symbol | CATCH BASIN/PIT | Catch Basin/Pit Symbol | CATCH BASIN/PIT |
| Culvert Symbol | CULVERT | Culvert Symbol | CULVERT |
| Rock Lining/Dam Symbol | ROCK LINING/DAM | Rock Lining/Dam Symbol | ROCK LINING/DAM |
| Rock Wall/Retaining Wall Symbol | ROCK WALL/RETAINING WALL | Rock Wall/Retaining Wall Symbol | ROCK WALL/RETAINING WALL |
| Power Pole & Anchor/Light Standard Symbol | POWER POLE & ANCHOR/LIGHT STANDARD | Power Pole & Anchor/Light Standard Symbol | POWER POLE & ANCHOR/LIGHT STANDARD |
| Tree Symbol | TREE | Tree Symbol | TREE |
| Street Sign/Parking Meter Symbol | STREET SIGN/PARKING METER | Street Sign/Parking Meter Symbol | STREET SIGN/PARKING METER |
| 131.82 | ELEVATION/GRADE | 125.00 | ELEVATION/GRADE |
| Test Pit Symbol | TEST PIT | Test Pit Symbol | TEST PIT |
| Drainage/Swale Flow Direction Symbol | DRAINAGE/SWALE FLOW DIRECTION | Drainage/Swale Flow Direction Symbol | DRAINAGE/SWALE FLOW DIRECTION |
| Water Main/Service Symbol | WATER MAIN/SERVICE | Water Main/Service Symbol | WATER MAIN/SERVICE |
| SAN | SANITARY MANHOLE & PIPE | SAN | SANITARY MANHOLE & PIPE |
| STM | STORM MANHOLE & PIPE | STM | STORM MANHOLE & PIPE |
| SAN/STM | COMBINED PIPE | SAN/STM | COMBINED PIPE |
| GAS | GAS LINE | GAS | GAS LINE |
| FL | 100YR. FLOOD LIMIT | FL | 100YR. FLOOD LIMIT |
| Guard Rail Symbol | GUARD RAIL | Guard Rail Symbol | GUARD RAIL |
| Underground Conduit Symbol | UNDERGROUND CONDUIT | Underground Conduit Symbol | UNDERGROUND CONDUIT |
| Overhead Wires Symbol | OVERHEAD WIRES | Overhead Wires Symbol | OVERHEAD WIRES |
| Property Line/Boundary Symbol | PROPERTY LINE/BOUNDARY | Property Line/Boundary Symbol | PROPERTY LINE/BOUNDARY |
| Fence Symbol | FENCE | Fence Symbol | FENCE |
| Building Symbol | BUILDING | Building Symbol | BUILDING |
| Top of Slope Symbol | TOP OF SLOPE | Top of Slope Symbol | TOP OF SLOPE |
| Toe of Slope Symbol | TOE OF SLOPE | Toe of Slope Symbol | TOE OF SLOPE |
| Treeline Symbol | TREELINE | Treeline Symbol | TREELINE |
| Limits of Disturbance Symbol | LIMITS OF DISTURBANCE | Limits of Disturbance Symbol | LIMITS OF DISTURBANCE |
| Tactile Pedestrian Plates Symbol | TACTILE PEDESTRIAN PLATES | Tactile Pedestrian Plates Symbol | TACTILE PEDESTRIAN PLATES |
| Project Safety Signage Symbol | PROJECT SAFETY SIGNAGE | Project Safety Signage Symbol | PROJECT SAFETY SIGNAGE |
| Orange Sawhorse Barricade Symbol | ORANGE SAWHORSE BARRICADE | Orange Sawhorse Barricade Symbol | ORANGE SAWHORSE BARRICADE |

NOTES

1. THIS PLAN IS IN METRIC.

| No. | YY/MM/DD | Revision Description | Appr'd |
|-----|----------|----------------------|--------|
| 0 | 21/02/10 | ISSUED FOR REVIEW | |

SDMM
 Servant, Dunbrack, McKenzie & MacDonald Ltd.
 NOVA SCOTIA LAND SURVEYORS & CONSULTING ENGINEERS

36 GLAND CRESCENT
 BAYERS LAKE BUSINESS PARK
 HALIFAX, NS B5S 1C8

PHONE: (902) 455-1537
 FAX: (902) 455-8479
 WEB: www.sdmm.co

CUNARD BUILDING
 1325 LOWER WATER STREET
 HALIFAX, NOVA SCOTIA

CONCRETE DELIVERY SCHEMATIC

| | | | | | |
|-----------|------------------|----------|-------------|--------------|--------------------------|
| Date | February 8, 2021 | Drawn | D. ANDERSON | Project No. | FILE NO. 1-1-144 (35804) |
| Scale | 1:250 | Engineer | G. MACLEAN | Plan No. | 16-2482-0 |
| Reference | Approved | Approved | G. MACLEAN | Drawing Name | R2 |
| Surveyed | Sheet | | | | |



Appendix Q – Crane Information

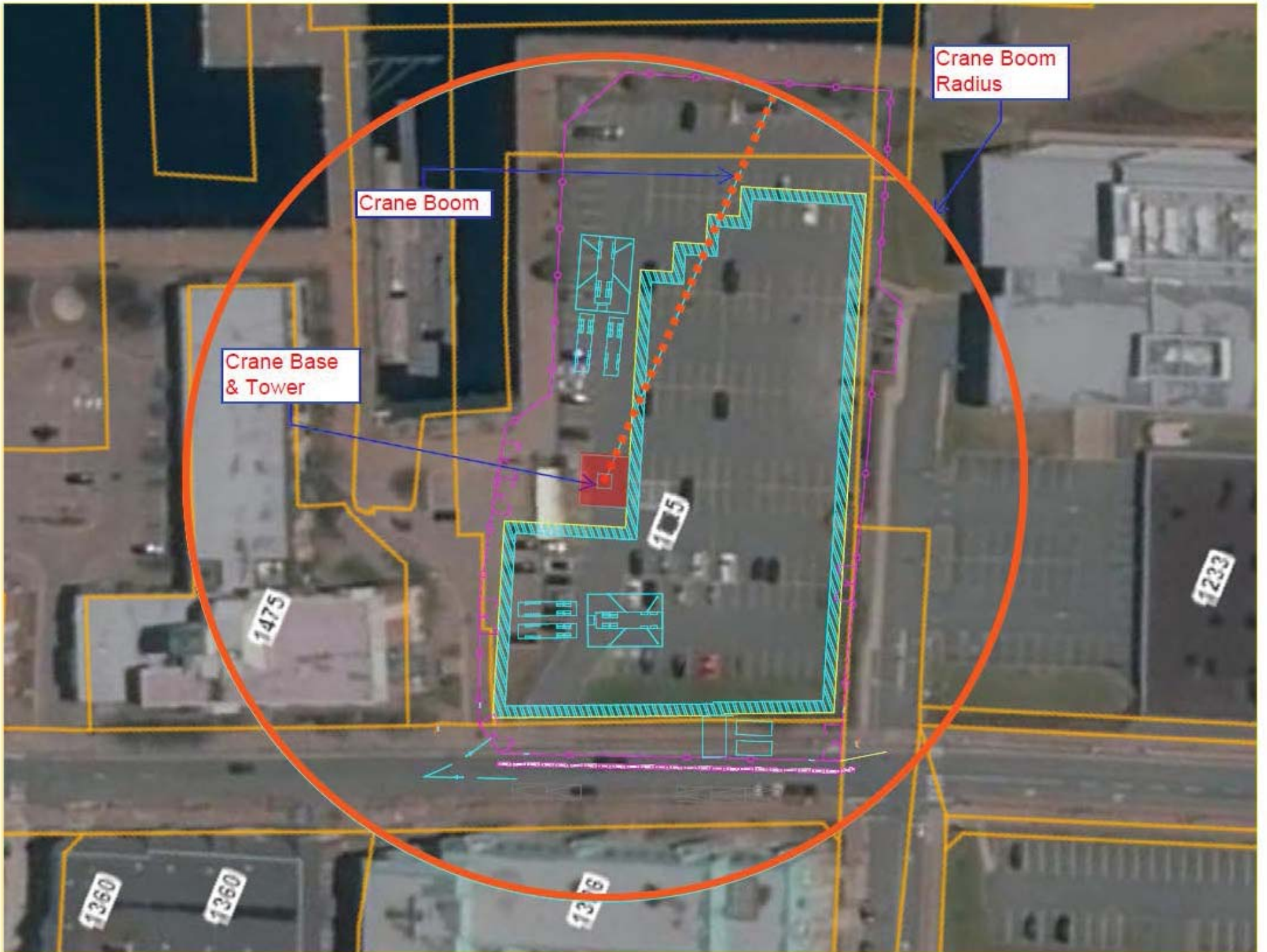

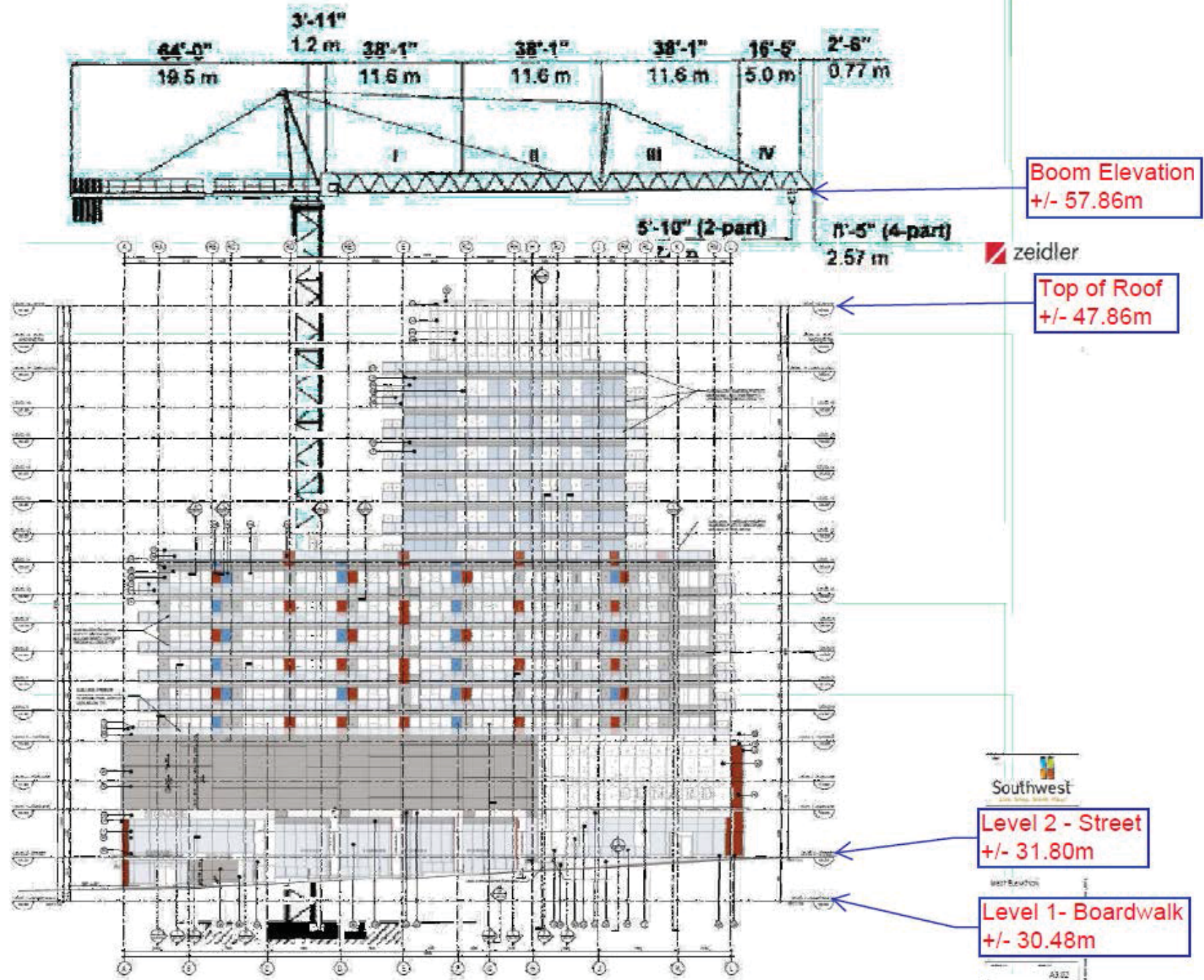



PEINER SK 315

Hammerhead Tower Crane
 17,600-35,300 lbs. (8-16 mt)
 Lifting Capacity

SPECIFICATIONS

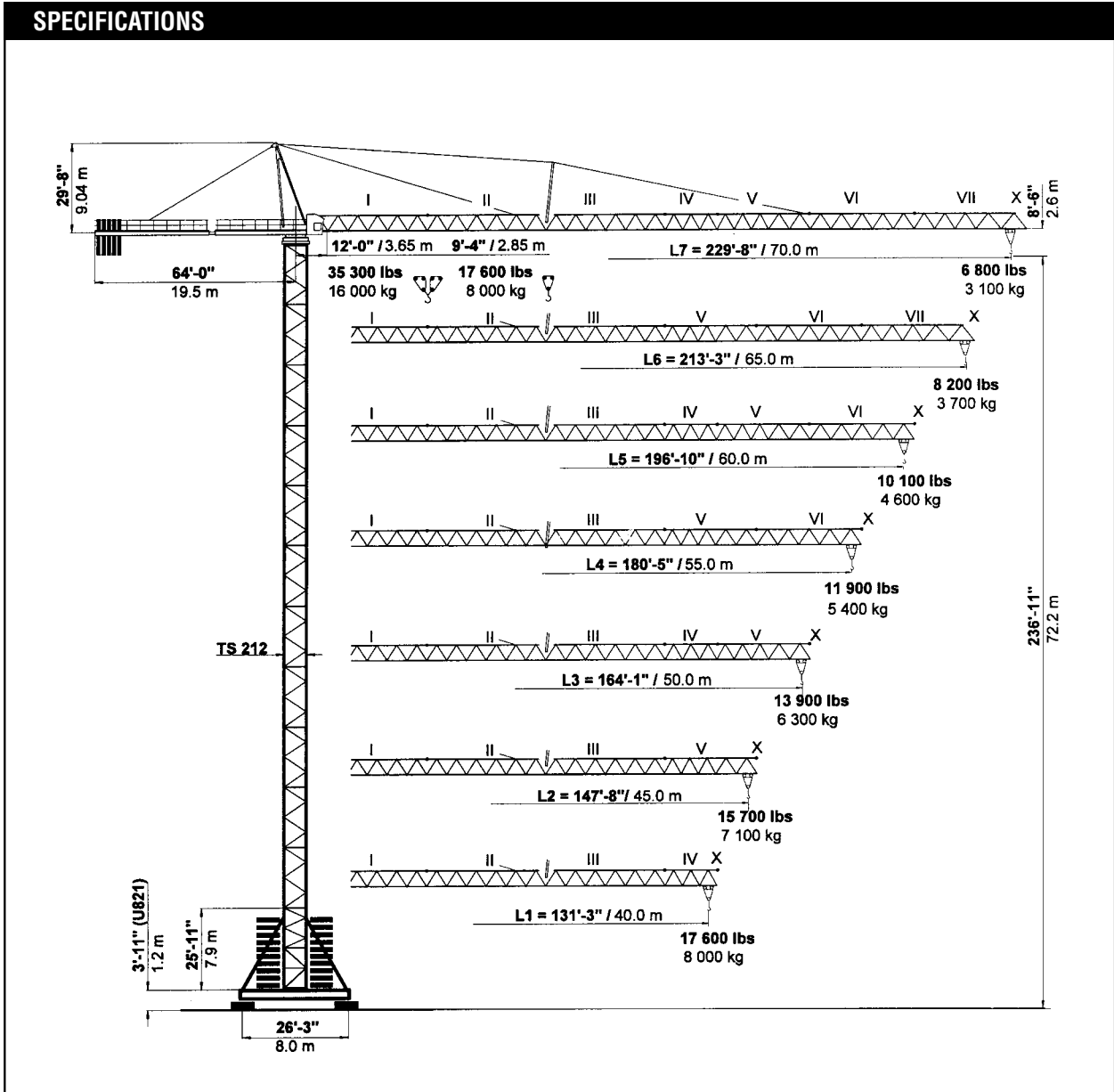

simple, available and
 cost effective™

Machines shown may have optional equipment.



PEINER SK 315

Combinations of tower section, hook heights, forces acting per corner, base ballast

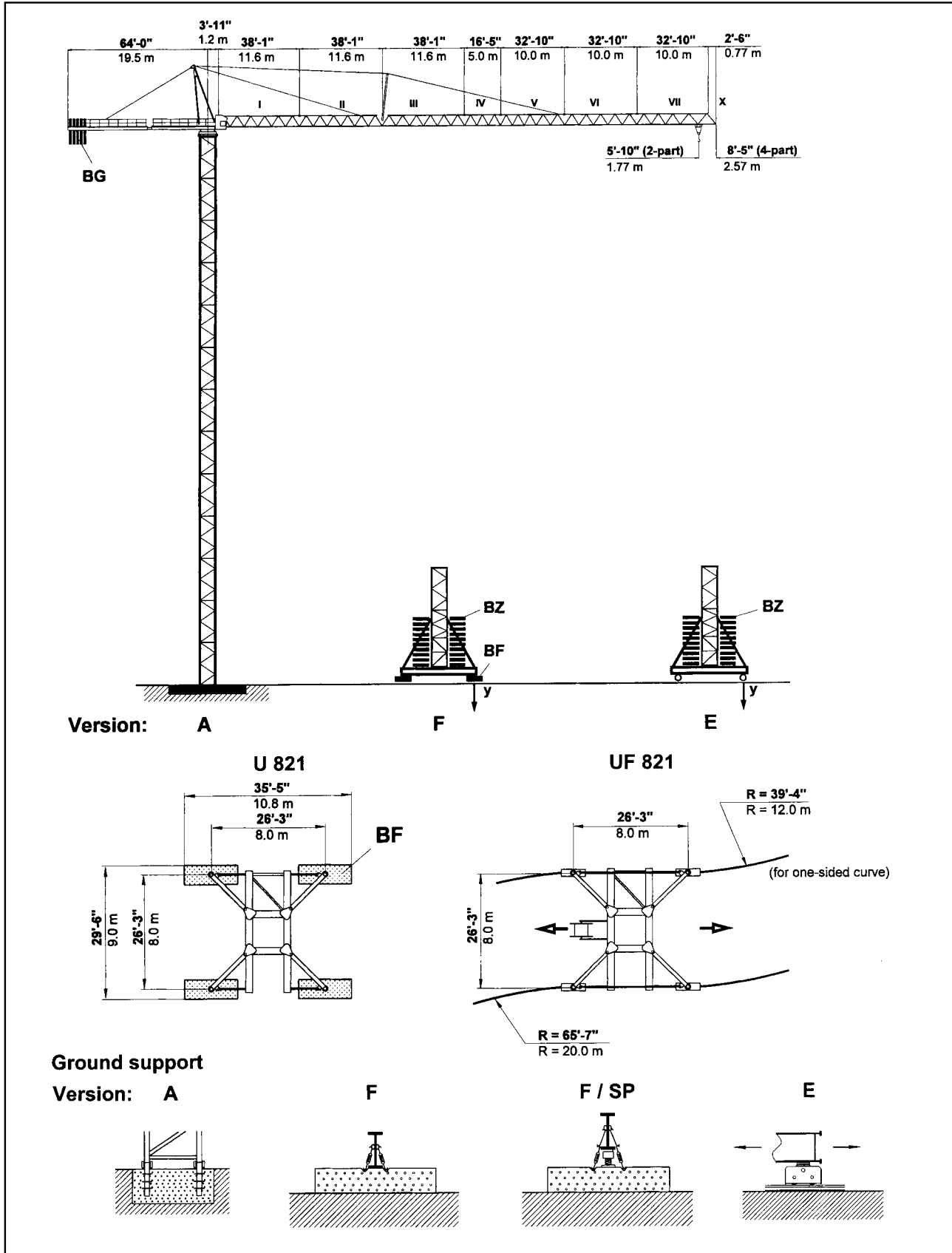

PEINER SK 315 Tower TS 211

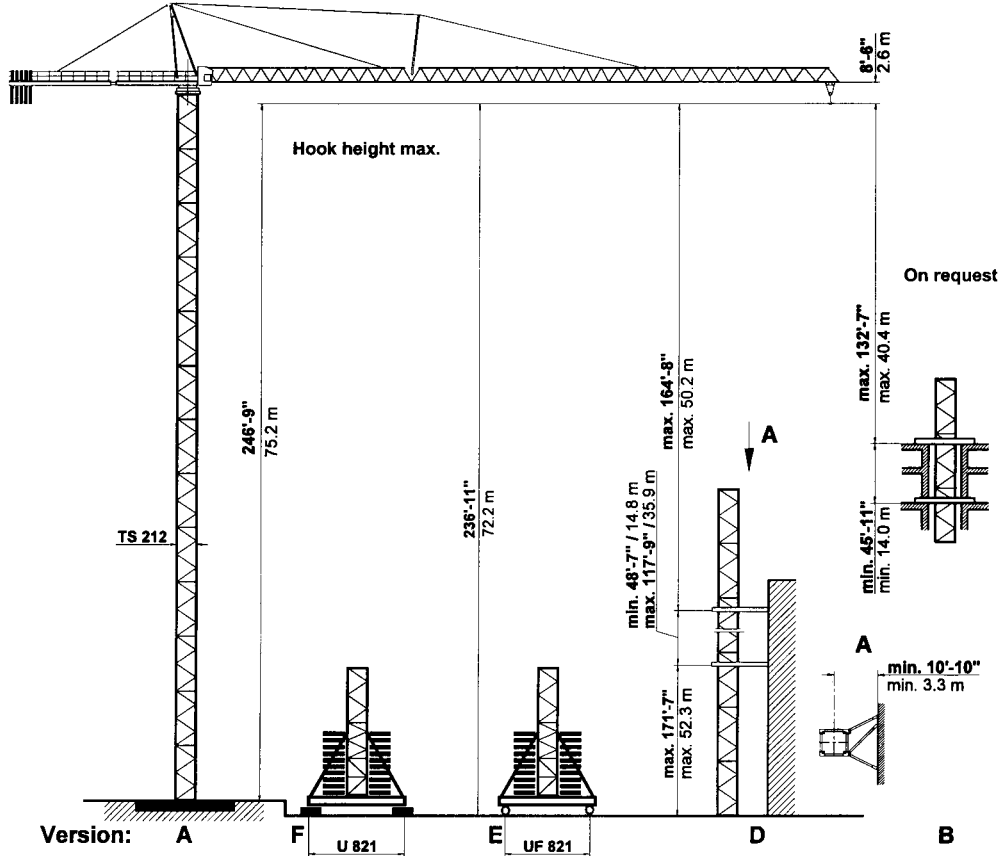

| TS 212 | Version A | | Version F | | | Version E | | | | |
|--|-----------|-------|----------------------------------|-----------|---------------------------------------|---------------------------|-------------------------|----------|------------|----------------|
| | Tower | HH | Tower | HH | BZ + BF | in service | out of service | BZ | in service | out of service |
| TS 212.1 | ft | m | TSV 212 | ft | kips / t | kips / kN | kips / kN | kips / t | kips / kN | kips / kN |
| 13 x TS 212.1 | 246'-9"* | 75.2* | | | | | | | | |
| 12 x TS 212.1 | 227'-4"* | 69.3* | 1 x TSV 212 | 236'-11"* | 212.0 | 204 | 279 | 198.0 | 212 | 282 |
| | | | 11 x TS 212.1 | 72.2* | 96 | 909 | 1243 | 90 | 942 | 1253 |
| 11 x TS 212.1 | 208'-0"* | 63.4* | 1 x TSV 212 | 217'-6"* | 168.0 | 186 | 240 | 154.0 | 192 | 242 |
| | | | 10 x TS 212.1 | 66.3* | 76 | 826 | 1066 | 70 | 856 | 1075 |
| 10 x TS 212.1 | 188'-8"* | 57.5* | 1 x TSV 212 | 198'-2" | 146.0 | 173 | 203 | 132.0 | 179 | 204 |
| | | | 9 x TS 212.1 | 60.4 | 66 | 770 | 901 | 60 | 797 | 909 |
| 9 x TS 212.1 | 169'-4" | 51.6 | 1 x TSV 212 | 178'-10" | 124.0 | 161 | 169 | 88.0 | 161 | 169 |
| | | | 8 x TS 212.1 | 54.5 | 56 | 715 | 751 | 40 | 715 | 754 |
| 8 x TS 212.1 | 149'-11" | 45.7 | 1 x TSV 212 | 159'-5" | 101.0 | 149 | 145 | 88.0 | 154 | 170 |
| | | | 7 x TS 212.1 | 48.6 | 46 | 661 | 645 | 40 | 683 | 654 |
| 7 x TS 212.1 | 130'-7" | 39.8 | 1 x TSV 212 | 140'-1" | 101.0 | 142 | 128 | 66.0 | 141 | 124 |
| | | | 6 x TS 212.1 | 42.7 | 46 | 633 | 569 | 30 | 629 | 553 |
| 6 x TS 212.1 | 111'-3" | 33.9 | 1 x TSV 212 | 120'-9" | 101.0 | 136 | 112 | 66.0 | 135 | 108 |
| | | | 5 x TS 212.1 | 36.8 | 46 | 607 | 499 | 30 | 600 | 482 |
| 5 x TS 212.1 | 91'-10" | 28.0 | 1 x TSV 212 | 101'-5" | 101.0 | 131 | 98 | 66.0 | 129 | 94 |
| | | | 4 x TS 212.1 | 30.9 | 46 | 582 | 435 | 30 | 573 | 418 |
| 4 x TS 212.1 | 72'-6" | 22.1 | 1 x TSV 212 | 82'-0" | 101.0 | 126 | 85 | 66.0 | 123 | 81 |
| | | | 3 x TS 212.1 | 25.0 | 46 | 559 | 376 | 30 | 548 | 359 |
| 3 x TS 212.1 | 53'-2" | 16.2 | 1 x TSV 212 | 62'-8" | 101.0 | 120 | 80 | 66.0 | 118 | 75 |
| | | | 2 x TS 212.1 | 19.1 | 46 | 536 | 356 | 30 | 523 | 335 |
| 2 x TS 212.1 | 33'-9" | 10.3 | 1 x TSV 212 | 43'-4" | 101.0 | 116 | 80 | 66.0 | 112 | 75 |
| | | | 1 x TS 212.1 | 13.2 | 46 | 515 | 356 | 30 | 500 | 335 |
| Foundation 25'-7" x 25'-7" x 5'-7" 7.8 x 7.8 x 1.7 m | | | Stationary base U 821 | | | Travelling base UF 821 | | | | |
| Anchor stools 4 x FF 212 | | | BF 4 x 8.82 kips 4 x 4.0 t | | BZ block 11.02 kips Block 5.0 t | | Bogle Curve F 500 | | | |

If TSK 212 section is used the hook height is increased by 6'-7" (2 m).

* Lower climbing section after erection.



TS 212.1 = 19'-4 1/4" / 5.9 m

TSV 212 = 25'-11" / 7.9 m











TSK 212 = 6'-7" / 2.0 m



PEINER SK 315 Radius and Capacity

| Jib | Max. capacity max. 17,600 lbs 8.0 t | Radius – ft./m Capacity – lbs./mt | | | | | | | | | | | | | | | | | | | |
|---------|---|--|---------------|---------------|----------------|---------------|---------------|---------------|---------------|---------------|----------------|---------------|---------------|----------------|---------------|---------------|---------------|--------------------------|-------------|--|--|
| | | 2-Part Line  max. 17,600 lbs max. 8.0 t | | | | | | | | | | | | | | | | | | | |
| ft m | | 75'-6" 23 | 82'-0" 25 | 98'-5" 30 | 114'-10" 35 | 131'-3" 40 | 141'-1" 43 | 147'-8" 45 | 157'-6" 48 | 164'-1" 50 | 173'-11" 53 | 180'-5" 55 | 190'-3" 58 | 196'-10" 60 | 206'-8" 63 | 213'-3" 65 | 223'-1" 68 | 229'-8" 70 | | | |
| L7 | 229'-8" 70.0 | 9'-4" - 96'-9" 2.85 - 29.5 m | 17600 8.0 | 17600 8.0 | 17400 7.9 | 14800 6.7 | 12800 5.8 | 11900 5.4 | 11200 5.1 | 10600 4.8 | 10100 4.6 | 9500 4.3 | 9000 4.1 | 8600 3.9 | 8200 3.7 | 7700 3.5 | 7500 3.4 | 7100 3.2 | 6800 3.1 | | |
| L6 | 213'-3" 65.0 | 9'-4" - 105'-0" 2.85 - 32.0 m | 17600 8.0 | 17600 8.0 | 17600 8.0 | 16100 7.3 | 13900 6.3 | 13000 5.9 | 12300 5.6 | 11500 5.2 | 11000 5.0 | 10400 4.7 | 9900 4.5 | 9300 4.2 | 8800 4.0 | 8600 3.9 | 8200 3.7 | | | | |
| L5 | 196'-10" 60.0 | 9'-4" - 117'-9" 2.85 - 35.9 m | 17600 8.0 | 17600 8.0 | 17600 8.0 | 17600 8.0 | 15700 7.1 | 14600 6.6 | 13900 6.3 | 13000 5.9 | 12300 5.6 | 11700 5.3 | 11200 5.1 | 10600 4.8 | 10100 4.6 | | | | | | |
| L4 | 180'-5" 55.0 | 9'-4" - 124'-8" 2.85 - 38.0 m | 17600 8.0 | 17600 8.0 | 17600 8.0 | 17600 8.0 | 16800 7.6 | 15400 7.0 | 14800 6.7 | 13900 6.3 | 13200 6.0 | 12300 5.6 | 11900 5.4 | | | | | | | | |
| L3 | 164'-1" 50.0 | 9'-4" - 130'-11" 2.85 - 39.9 m | 17600 8.0 | 17600 8.0 | 17600 8.0 | 17600 8.0 | 17600 8.0 | 16300 7.4 | 15400 7.0 | 14600 6.6 | 13900 6.3 | | | | | | | | | | |
| L2 | 147'-8" 45.0 | 9'-4" - 131'-11" 2.85 - 40.2 m | 17600 8.0 | 17600 8.0 | 17600 8.0 | 17600 8.0 | 17600 8.0 | 16500 7.5 | 15700 7.1 | | | | | | | | | | | | |
| L1 | 131'-3" 40.0 | 9'-4" - 131'-3" 2.85 - 40.0 m | 17600 8.0 | 17600 8.0 | 17600 8.0 | 17600 8.0 | | | | | | | | | | | | | | | |
| ft m | 35,300 lbs 16.0 t | 4-Part Line  max. 35,300 lbs max. 16.0 t | | | | | | | | | | | | | | | | Radius - 2'-7" (- 0.8 m) | | | |
| L7 | 227'-0" 69.2 | 12'-0" - 48'-7" 3.65 - 14.8 m | 21800 9.9 | 19600 8.9 | 16100 7.3 | 13200 6.0 | 11200 5.1 | 10400 4.7 | 9700 4.4 | 9000 4.1 | 8600 3.9 | 7900 3.6 | 7500 3.4 | 7100 3.2 | 6600 3.0 | 6200 2.8 | 6000 2.7 | 5500 2.5 | 5300 2.4 | | |
| L6 | 210'-8" 64.2 | 12'-0" - 52'-2" 3.65 - 15.9 m | 23800 10.8 | 21600 9.8 | 17400 7.9 | 14600 6.6 | 12600 5.7 | 11500 5.2 | 10800 4.9 | 9900 4.5 | 9500 4.3 | 8800 4.0 | 8400 3.8 | 7700 3.5 | 7500 3.4 | 6800 3.1 | 6600 3.0 | | | | |
| L5 | 194'-3" 59.2 | 12'-0" - 57'-9" 3.65 - 17.6 m | 26900 12.2 | 24500 11.1 | 19800 9.0 | 16800 7.6 | 14300 6.5 | 13000 5.9 | 12300 5.6 | 11500 5.2 | 10800 4.9 | 10100 4.6 | 9700 4.4 | 9000 4.1 | 8600 3.9 | | | | | | |
| L4 | 177'-10" 54.2 | 12'-0" - 61'-0" 3.65 - 18.6 m | 28700 13.0 | 26000 11.8 | 21200 9.6 | 17900 8.1 | 15200 6.9 | 14100 6.4 | 13200 6.0 | 12300 5.6 | 11700 5.3 | 10800 4.9 | 10400 4.7 | | | | | | | | |
| L3 | 161'-5" 49.2 | 12'-0" - 63'-8" 3.65 - 19.4 m | 30200 13.7 | 27300 12.4 | 22300 10.1 | 18700 8.5 | 16100 7.3 | 14800 6.7 | 14100 6.4 | 12800 5.8 | 12300 5.6 | | | | | | | | | | |
| L2 | 145'-0" 44.2 | 12'-0" - 64'-0" 3.65 - 19.5 m | 30400 13.8 | 27600 12.5 | 22500 10.2 | 19000 8.6 | 16300 7.4 | 15000 6.8 | 14100 6.4 | | | | | | | | | | | | |
| L1 | 128'-7" 39.2 | 12'-0" - 66'-3" 3.65 - 20.2 m | 31700 14.4 | 28700 13.0 | 23600 10.7 | 19800 9.0 | 17000 7.7 | | | | | | | | | | | | | | |

Speeds

| | | | | | | |
|---|--|--|---|---|--|--|
| FU 8-160/4 |  | v = 0 → ~290 fpm (88 m / min.) | 10.2 HP 7.5 kW | | | |
| SR 10-190/3 |  | v = 0 → ~96 fpm (30 m / min.) | 2 x 16.3 HP 2 x 12.0 kW | | | |
| K WB 120/4 |  | v = 0 → 0.9 rpm (min ⁻¹) | 2 x 11.4 HP 2 x 8.4 kW | | | |
|  HK max. = 705' (215 m) 6 - layers | | | 480 V / 60 Hz / 3 ph | | | |
| Type SR WB 66-80/4F [108 HP] [79 kW] |     |  2-Part Line → 444 fpm 134 m/min → 276 fpm 84 m/min → 180 fpm 54 m/min → 108 fpm 34 m/min |  4-Part Line → 5 500 lbs 2 500 kg → 9 300 lbs 4 200 kg → 13 900 lbs 6 300 kg → 17 600 lbs 8 000 kg |  2-Part Line → 222 fpm 67 m/min → 138 fpm 42 m/min → 90 fpm 27 m/min → 54 fpm 17 m/min | 11 000 lbs 5 000 kg 18 600 lbs 8 400 kg 27 800 lbs 12 600 kg 35 300 lbs 16 000 kg | Total motor output ~140 HP without SR 10-190/3 ~105 kW Connected power 170 kVA |

Counterweight

| Jib | | L 1 | L 2 | L 3 | L 4 | L 5 | L 6 | L 7 |
|---------------|-------|-------------------------|-------------------------|-------------------------|-------------------------|-------------------------|-------------------------|-------------------------|
| Counterweight | BG | 30 000 lbs 13 600 kg | 32 200 lbs 14 600 kg | 36 600 lbs 16 600 kg | 39 150 lbs 17 750 kg | 43 550 lbs 19 750 kg | 41 350 lbs 18 750 kg | 45 750 lbs 20 750 kg |
| | [lbs] | 3 x 6 950 1 x 9 150 | 2 x 6 950 2 x 9 150 | 4 x 9 150 | 3 x 6 950 2 x 9 150 | 1 x 6 950 4 x 9 150 | 2 x 6 950 3 x 9 150 | 5 x 9 150 |
| | [t] | 3 x 3.15 1 x 4.15 | 2 x 3.15 2 x 4.15 | 4 x 4.15 | 3 x 3.15 2 x 4.15 | 1 x 3.15 4 x 4.15 | 2 x 3.15 3 x 4.15 | 5 x 4.15 |
| | | | | | | | | |



PEINER SK 315 Dimensions and transport weights

See operating manual for mounting weights

| | Designation | | Dimensions (ft / m) | | | Weight | Volume |
|----|---|---------------------|---------------------|------|-------|---------|----------|
| | | | l | b | h | lbs / t | ft³ / m³ |
| 1 | Jib Section III | | 39.01 | 4.99 | 7.09 | 4 200 | 1 386 |
| | | | 11.94 | 1.52 | 2.16 | 1.92 | 39.2 |
| 2 | Jib Section I | | 39.01 | 4.99 | 5.84 | 3 790 | 1 137 |
| | Section II | | 11.89 | 1.52 | 1.78 | 1.72 | 32.2 |
| | Section III | | 38.65 | 4.99 | 6.17 | 4 320 | 1 190 |
| | Section IV | | 11.78 | 1.52 | 1.88 | 1.96 | 33.7 |
| | Section V | | 19.19 | 4.99 | 5.41 | 1 760 | 519 |
| | Section VI | | 5.85 | 1.52 | 1.65 | 0.80 | 14.7 |
| | Section VII | | 35.34 | 4.99 | 5.45 | 3 090 | 961 |
| | Jib tip X | | 10.77 | 1.52 | 1.66 | 1.40 | 27.2 |
| | | | 36.03 | 4.99 | 5.48 | 2 470 | 985 |
| 3 | Turntable with slewing ring support and cabin | | 36.35 | 7.64 | 7.81 | 25 350 | 2 169 |
| | | | 11.08 | 2.33 | 2.38 | 11.50 | 61.4 |
| | Turntable with slewing ring support | | 31.99 | 7.64 | 7.81 | 24 030 | 1 911 |
| | | 9.75 | 2.33 | 2.38 | 10.90 | 54.1 | |
| | Cabin with support and railing | | 10.17 | 4.92 | 7.25 | 1 320 | 364 |
| | | | 3.10 | 1.50 | 2.21 | 0.60 | 10.3 |
| 4 | Counter jib with hoist winch | | 38.13 | 5.91 | 6.00 | 14 550 | 1 353 |
| | | | 11.62 | 1.80 | 1.83 | 6.60 | 38.3 |
| | Hoist winch | 66 WB | 7.51 | 5.45 | 3.28 | 5 400 | 134 |
| | | | 2.29 | 1.66 | 1.00 | 2.45 | 8.4 |
| 5 | Counterweight | BG | 3.94 | 1.64 | 9.32 | 6 950 | 60 |
| | | | 1.20 | 0.50 | 2.84 | 3.15 | 1.4 |
| | | | 3.94 | 1.64 | 12.11 | 9 150 | 78 |
| | | | 1.20 | 0.50 | 3.69 | 4.15 | 1.7 |
| 6 | Tower section | TS 212.1 | 19.52 | 7.78 | 8.01 | 9 130 | 1 216 |
| | | | 5.95 | 2.37 | 2.45 | 4.14 | 34.4 |
| | | TSV 212 with struts | 31.17 | 9.84 | 10.00 | 20 330 | 3 067 |
| | | 9.50 | 3.00 | 3.05 | 9.22 | 86.9 | |
| | TSK 212 | 6.63 | 7.87 | 9.84 | 6 170 | 513 | |
| | | 2.02 | 2.40 | 3.00 | 2.80 | 14.5 | |
| 7 | Travelling base, folded | UF 821 | 41.01 | 9.74 | 7.05 | 35 050 | 2 816 |
| | | | 12.5 | 2.97 | 2.15 | 15.90 | 79.8 |
| 8 | Stationary base, folded | U 821 | 34.55 | 9.06 | 2.79 | 17 130 | 873 |
| | | | 10.53 | 2.76 | 0.85 | 7.77 | 24.7 |
| 9 | Central ballast block | BZ | 11.48 | 4.92 | 2.20 | 11 020 | 124 |
| | | | 3.50 | 1.50 | 0.67 | 5.00 | 3.5 |
| 10 | Foundation pad | BF | 9.19 | 3.28 | 1.87 | 8 820 | 57 |
| | | | 2.80 | 1.00 | 0.57 | 4.00 | 1.6 |
| 11 | Accessories | | | | | 4 800 | |
| | | | | | | 2.17 | |



For more information, product demonstration, or details on lease and rental plans, please contact your local Terex Towers Distributor.

We reserve the right to amend these specifications at any time without notice. The only warranty applicable is our standard written warranty applicable to the particular product and sale. We make no other warranty, expressed or implied.

Bigge Crane and Rigging Co.

10700 Bigge Avenue
San Leandro, CA 94577
Phone: (888) 337-BIGGE or (510) 638-8100
Fax: (510) 639-4053
Email: towers@bigge.com
Web site: www.biggetowercrane.com

 **TEREX TOWERS**

202 Raleigh Street
Wilmington, NC 28412 USA
(910) 395-8500 • FAX: (910) 395-8547
E-mail: wilmington@terexlifting.com



www.terexlift.com





**Quality
Concrete
Inc.**

Weathermix

20 MacDonald Ave
Dartmouth, NS, B3B 1C5
Phone: (902) 468-8040
Fax: (902) 468-2730

"Our business is concrete."

Weathermix is a concrete mix intended to assist in cold weather placing conditions in conjunction with proper cold weather concreting procedures. Although Weathermix is not antifreeze, it does accelerate set times to help provide early protection from freezing.

Weathermix does not contain calcium-chloride or any other intentionally added chlorides making it the ideal choice for set acceleration in areas where steel is present.

The table below outlines the recommended use of Weathermix to help extend your concrete placements during our winter construction season.

| Ambient Temperature | Order | \$ extra per cubic meter |
|---------------------|--------------|--------------------------|
| 10 - 8 | Weathermix 1 | 15.00 |
| 7 - 5 | Weathermix 2 | 19.00 |
| 4 - 2 | Weathermix 3 | 24.00 |
| 1 - -1 | Weathermix 4 | 30.00 |
| -2 - -4 | Weathermix 5 | 35.00 |
| -5 - -7 | Weathermix 6 | 40.00 |
| < -8 | Weathermix 7 | 49.00 |
| < -8 | Weathermix 8 | 55.00 |

Weathermix Benefits:

- Extended construction season
- Accelerated set time
- High-early strengths
- Potential for lower labor costs
- Maintain Workability